

Kodak

Archive Writer
Interface Software

User's Guide

A-61056
Part No. 3E9644
CAT No. 881 4832

**EASTMAN KODAK COMPANY
SOFTWARE LICENSE AGREEMENT**

Read the following terms and conditions carefully before using this Software. Use of this Software indicates your acceptance of these terms and conditions. If you do not agree with them, you should promptly return the package in its entirety for a full refund.

LICENSE

Grant of License. Eastman Kodak Company ("Kodak") grants you a license to use one copy of the enclosed software program(s) (the "Software") subject to the license restrictions set forth below.

Restrictions on Use. You may use the Software only on one computer at a time. For each additional computer on which the Software is running at the same time, you will need an additional licensed copy of the Software. You may copy the Software as necessary to enable you to use the Software as described above.

Transfer of the Software. You may permanently transfer the Software to another party if the other party agrees to accept the terms and conditions of this license and you retain no copies of the Software.

Copyright. The Software is owned by Kodak or its suppliers and protected by copyright laws and international treaties. You may not copy the Software other than as expressly provided in this license. You may not reverse engineer, decompile, or disassemble the Software. If this Software is used within a country of the European Union, nothing in this Agreement shall be construed as restricting any rights available under the European Community Software Directive (91/250/EEC).

Term. This license is effective until terminated. You may terminate it at any time by destroying the Software together with all copies in any form. It will also terminate if you fail to comply with any term or condition of this Agreement. You agree upon such termination to destroy the Software together with all copies in any form.

LIMITED WARRANTY

For a period of 90 days after the date of delivery of the Software to you, as evidenced by a copy of your purchase receipt, Kodak warrants (i) the Software will perform substantially in accordance with the accompanying written materials, and (ii) the media on which the Software is furnished will be free from defects in materials and workmanship under normal use.

Kodak does not warrant that the functions contained in the Software will meet your requirements or that the operation of the Software will be uninterrupted or error free. You assume responsibility for operation of the Software to achieve your intended results, and for the installation, use, and results obtained from the Software.

Subject to any applicable legislation which prohibits the following exclusions, KODAK MAKES NO OTHER WARRANTIES OF ANY KIND, EITHER EXPRESS OR IMPLIED, INCLUDING THE IMPLIED WARRANTIES OF MERCHANTABILITY AND FITNESS FOR A PARTICULAR PURPOSE. Some states and countries, including Australia, do not allow the exclusion of implied warranties, or have legislation that imposes certain statutory warranties that cannot be excluded, so the above exclusion may not apply to you. This warranty gives you specific legal rights and you may also have other rights.

LIMITATIONS OF REMEDIES

Subject to any applicable legislation which prohibits the following limitations, Kodak's entire liability and your exclusive remedy shall be, at Kodak's option either (a) the repair or replacement of the Software or any media not meeting Kodak's "Limited Warranty" that is returned to Kodak or your dealer with a copy of your receipt, or (b) the return of the price you paid for the Software, provided you have proof of the purchase price you paid. These remedies are not available if failure of the Software or media is the result of misuse, abuse, or a failure to follow the operating instructions in the accompanying written materials.

IN NO EVENT WILL KODAK OR ITS SUPPLIERS OR DEALERS BE LIABLE TO YOU FOR ANY INCIDENTAL OR CONSEQUENTIAL DAMAGES, INCLUDING ANY LOST PROFITS, LOST SAVINGS, OR OTHER DAMAGES ARISING OUT OF THE USE OR INABILITY TO USE THE SOFTWARE EVEN IF ADVISED OF THE POSSIBILITY OF SUCH DAMAGES. Some states and countries, including Australia, do not allow the limitation or exclusion of liability for incidental or consequential damages, or have legislation which restricts the limitation or exclusion of liability, so the above limitation may not apply to you.

GENERAL

If the Software was purchased in the United States, this Agreement is governed by the laws of the State of New York. If purchased outside the United States, this Agreement is governed by the laws of the country in which it was purchased.

U.S. GOVERNMENT RESTRICTED RIGHTS

The SOFTWARE and documentation are provided with RESTRICTED RIGHTS. Use, duplication, or disclosure by the Government is subject to restrictions as set forth in subdivision (c)(1)(ii) of The Rights in Technical Data and Computer Software clause DFAR 252.227-7013 or such other applicable government or agency regulation providing equivalent protection. Contractor / manufacturer is Eastman Kodak Company, 343 State Street, Rochester, New York, 14650.

1 Introduction

About this guide

The *Kodak Imagelink* Archive Writer Interface Software application provides a high-level interface to the *Kodak Digital Science* Document Archive Writer 4800 and the *Kodak* i9600 Series Writers. It also provides a set of restricted functions for administrative tasks involved in using the software.

Throughout this manual, the term **Writer** is used to describe both the *Kodak Digital Science* Document Archive Writer 4800 and the *Kodak* i9600 Series Writer. Any differences between the two Writers will be noted. This guide contains information and procedures necessary for setting up and running the *Kodak Imagelink* Archive Writer Interface Software (AWIS).

Organization

In addition to this chapter, the AWIS User's Guide is organized as follows:

Chapter 2, *Installing AWIS*: Provides hardware and software system requirements, instructions for installing an upgraded version of AWIS and how to start and exit AWIS.

Chapter 3, *AWIS Administration*: Describes each screen in AWIS Administration, including explanations of each field as well as procedures on how to set up applications, Writers and film templates.

Chapter 4, *AWIS Application*: Describes each screen in AWIS Application, including explanations of each field as well as procedures on how to run a job.

Chapter 5, *Troubleshooting*: Describes problems you may encounter while using AWIS and provides a list of error codes.

Appendix A, *Input Modes*: Provides detailed information and examples regarding List files and Batch mode as well as information on how to create a List file.

Appendix B, *TIFFCHKR Functions*: Provides information about the TIFFCHKR function and how to use it.

Appendix C, *Glossary*: Provides a listing of terms associated with the Writer and AWIS.

Appendix D, *Index Formats, Image Addressing and Image Marks*

Appendix E, *Image File Specifications*: details the specifications of the digital image files to be written to film.

What is AWIS?

AWIS is a Microsoft Windows application that provides a fully functional interface to the *Kodak Digital Science* Document Archive Writer 4800 and the *Kodak i9600* Series Writer. It is intended for those customers who do not want to develop their own application and whose needs do not require that the functionality provided by the application be completely integrated into their own existing software systems.

AWIS includes the following components:



AWIS Administration – allows access to all administrative functions. See *Chapter 3 - AWIS Administration*, for more information.

- Creates and maintains applications and film templates that define the film output (i.e., simplex, duplex, image marks, etc.).
- Defines the available Writers.
- Configures Poll mode.
- Configures performance parameters.
- Purges jobs.
- Generates reports.



AWIS Application – writes images using an application created via AWIS Administration. See *Chapter 4 - AWIS Application*, for more information.

- Controls and facilitates the transfer of image files from the imaging or scanning system to the Writer.
- Provides a status of Writer operations.
- Provides job status (i.e., Completed, Verified, Waiting for input, etc.) and verification.
- Generates the Transfer file that links the file name to the roll ID and image address, which are used to index the images for future retrievals.
- Generates reports.



TIFFCHKR Software – checks the image files before being written to film to assure the images are compliant with what the Writer and application definition expects. See *Appendix B – TIFFCHKR Functions*, for more information.

- Checks if required TIFF tags are present and have acceptable values.
- Checks if text files meet size restrictions or if they will be truncated.
- Validates compression format.
- Checks if the images meet scaling requirements and will fit across the width of the film.
- Checks if the images are located where indicated in the List file or Batch directory.
- Converts multi-strip images to single-strip images.
- Validates TIFF file size with the memory available on the Writer.



Awis.log – provides easy access to the Log file. See Chapter 3, “Error Logging tab” for more information.

What you need to know

Users of AWIS must understand the Microsoft Windows operating systems, including basic Windows terms and functions, and the basics of microfilm technology, especially image addressing.

For Windows, you must understand the following concepts; if you are not familiar with these terms, it is recommended you use the manuals accompanying your Windows software.

Button	Icon
Click	Mouse
Close	Program Manager
Dialog box	Pull-down menu
Double-click	Shift+click
Drop-down list	Single-click

Getting technical support

Read this section before contacting Kodak for technical support.

The following information is needed when contacting Kodak technical support for the AWIS Software. This procedure is current as of the date of this guide, but it may change without notice as conditions require.

Response Center assistance is available as part of the Service Agreement. Refer to the Service Agreement Terms and Conditions for hours of availability.

Only a trained System Administrator should place the call to the Kodak Response Center. The following items will be requested:

- A K-number that identifies the AWIS Software.
- A brief description of the question or problem.
- A contact name and a phone number where the contact/customer can be reached.

Phone numbers:

U.S. and Canada: 1-800-822-1414

International: 1-585-724-4675

The contact's name and phone number will be taken by a Response Center operator. A Response Center System Support Engineer will return the call.

The goal is to answer inquires on the first call. However, depending on the complexity of the question, it may be necessary to confer with other technical resources. Therefore, the inquiry may require follow-up contact.

Before calling the Response Center:

- Make sure that you have checked your input TIFF files with the TIFFCHKR application with the Multi-strip to Single-strip option enabled.
- Make sure you have changed the battery in your film cassette.

2 Installing AWIS

System requirements The following minimum hardware and software requirements are required to run AWIS.

Hardware

- 300 MHz Pentium II processor
- 64 MB RAM (128 MB recommended)
- At least 20 Gigabytes (GB) hard drive or enough space to hold the desired number of image files. It is recommended that the hard drive is at least 2 ½ times the size of the largest job you are running.
- CD ROM drive
- Monitor, keyboard, mouse
- Ethernet adapter compatible with IEEE 802.3 Ethernet. 3Com EtherLink III has been tested and is recommended for interfacing with the Writer
- Cabling from PC to Writer

Software

Microsoft Windows NT, v4.0 Client and Server version with Service Pack 4, Windows 2000 Client and Server.

Upgrading AWIS

Installing a new system requires other setup procedures, which are not documented below. Professional services are available for installing a new system. Contact your local Kodak Field Engineer for information regarding the *Kodak Imagelink* Digital Document Archive System Pre-Installation Accreditation.

If you want to upgrade AWIS from Versions 1.3 or greater, you can use the following Windows procedure:

1. Place the AWIS CD in the CD drive.
2. From the Start menu, select **Start > Run**.
3. Type `x:\setup` where *x* is the letter of your CD drive.
4. Click **OK**.
5. Follow the instructions on the screen.

When the upgrade process is complete, icons for AWIS Administration, AWIS Application, TIFFCHKR and AWIS.log will appear on the desktop, as well as be displayed under the Programs menu.

NOTE: The Writer must be rebooted to activate any firmware changes associated with this release.

Starting the software

To start AWIS:

1. In the Windows Start menu, select **Programs>AWIS**. The AWIS menu contains the Archive Writer Interface Software (AWIS), AWIS Administration, AWIS.log and TIFFCHKR.
2. Select the AWIS module you want to work with, AWIS Administration, AWIS Application, TIFFCHKR or AWIS.log.

Refer to the following chapters for more information:

- Chapter 3, AWIS Administration
- Chapter 4, AWIS Application
- Appendix B, TIFFCHKR Functions
- Chapter 3, “File menu – Error logging tab”, AWIS.log

Exiting the software

From the File menu, select **Exit**.

3 AWIS Administration

This chapter provides an overview of the windows you have access to when using AWIS Administration, as well as procedures for setting up applications, film templates, defining a Writer, removing jobs from the system and printing a report.

See *Chapter 4, AWIS Application* for an overview of the windows in AWIS Application and procedures for running jobs.

- From the Start menu, select **Programs > AWIS Administration** or click on the AWIS Administration icon.



The AWIS Administration window is displayed.

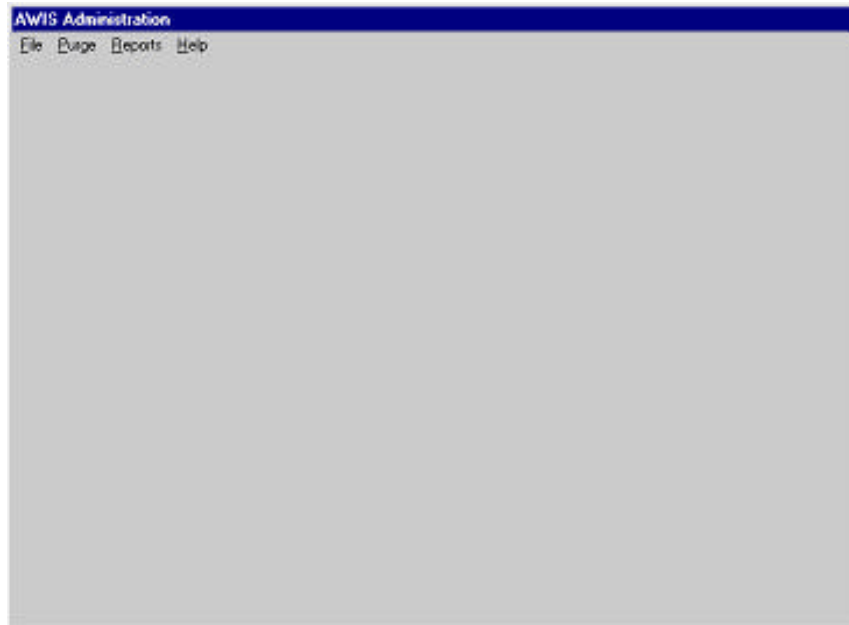

The menu bar provides the following options:

File — allows you to set up applications, define Writers and film templates, provides access to the Advanced and Polling tabs and exit AWIS Administration.

Purge — allows you to delete a job and its associated files from the system.

Reports — allows you to print a report of current AWIS jobs.

Help — provides access to AWIS Administration help.

File Menu

The File menu contains the following options: Applications, Archive Writers, Film Templates, Options and Exit.

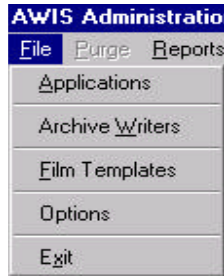

File menu — Applications

When you select **Applications** from the File menu, the AWIS Application Setup window is displayed. This window contains the following tabs: General, Begin Roll, End Roll, Transfer File, Error Logging, and Input Mode. Each tab allows you to set up an aspect of the application.

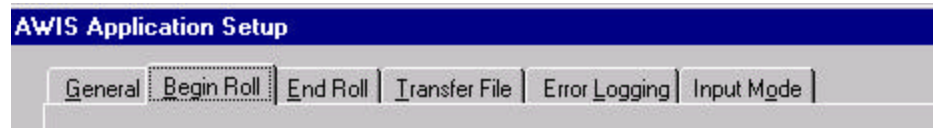

AWIS Application Setup

The buttons on the bottom of the AWIS Application Setup window apply to all of the tabs. If a button is grayed-out, it is not applicable for the active tab.

OK: saves the values on the tabs and closes the window.

Save: saves the values on the tabs, but does not close the window.

Delete: when the General tab is active, the selected application can be deleted. System-supplied default applications cannot be deleted.

Create: when the General tab is active, the Create New Application dialog box is displayed.

Cancel: closes the window without saving any changes.

Procedures on how to create new applications can be found in this chapter.

Application Setup — General tab

From the General tab, you can create or delete applications.

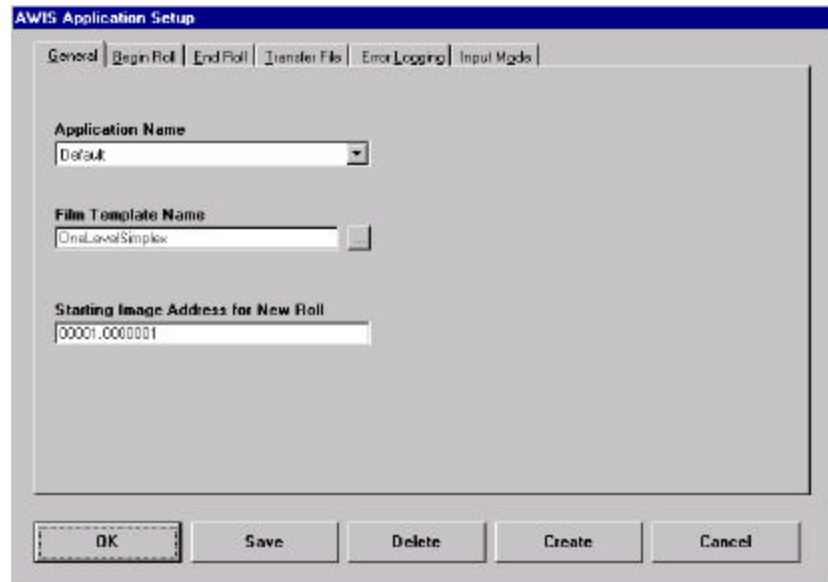

The screenshot shows the 'AWIS Application Setup' dialog box with the 'General' tab selected. The dialog has a title bar and a menu bar with options: General, Begin Roll, End Roll, Transfer File, Error Logging, and Input Mode. The main area contains three fields: 'Application Name' with a drop-down menu showing 'Default', 'Film Template Name' with a text box containing 'OnalLevelSimplex' and a browse button (...), and 'Starting Image Address for New Roll' with a text box containing '00001.0000001'. At the bottom, there are five buttons: OK, Save, Delete, Create, and Cancel.

Application Name — select the name of an existing application from the drop-down list or you can create a new application by selecting **Create**. For procedures on creating a new application, see the section entitled, “Setting up an application” later in this chapter.

Film Template Name — enter the name of an existing film template (up to 24 characters) or use the ... button to select from a list of existing film templates or create a new film template. For procedures on creating a new film template, see the section entitled, “Defining a film template” later in this chapter.

Starting Image Address for New Roll — enter the first image address for a new roll of film. This value must conform to the image addressing values defined in the film template. For more information see the section entitled, “Film Templates - Image Addressing tab” later in this chapter.

Application Setup — Begin Roll and End Roll tabs

The Begin Roll and End Roll tabs allow you to configure header and trailer page information. Header and trailer pages are images that can be added to the beginning and end of a roll of film to provide information such as the name of the job, responsible operator, date, resolution targets and error or job logs.

Header and trailer pages are not assigned an image address, and the frame containing them does not receive an image mark.

Each header and trailer page input file must be either a TIFF image file, or a text file, that conforms to the Writer's input file specifications. For more information, see *Appendix E, Image File Specifications*. AWIS converts any text files to TIFF format prior to writing to film. Header page files should be kept in a different directory than trailer page files. If a directory contains multiple files, the files within the directory are sorted and written to film using the Windows file sorting algorithm, so be sure to name the files accordingly in order to get the desired sequence on film.

Begin Roll tab:

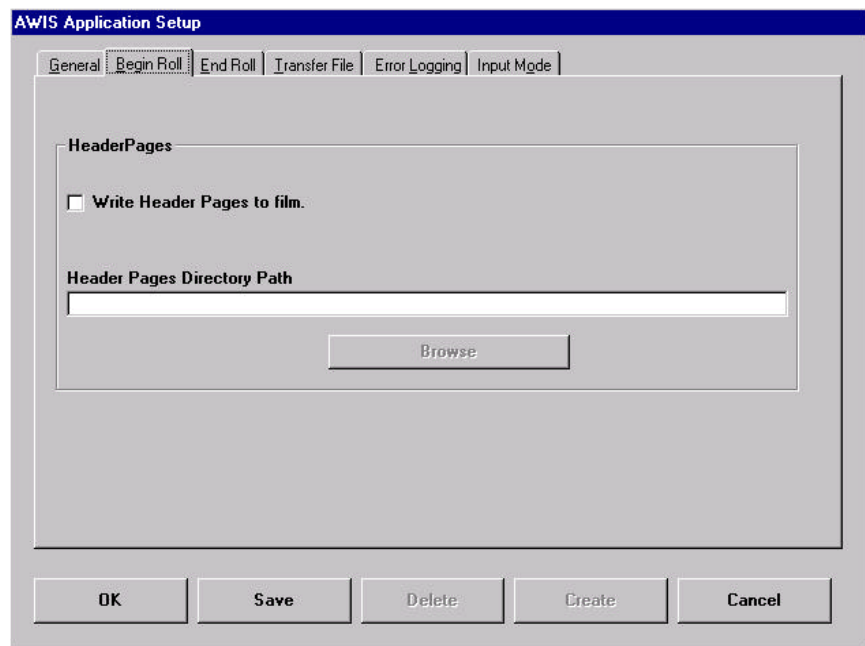

Write Header Pages to film — if checked, the header pages found in the Header Pages directory are written to film at the beginning of each roll prior to the first image designated via batch or list input.

Header Pages Directory Path — enter the path to a directory name where the header images reside or select **Browse** to display the Directory Selection window.

Browse — used to display the Directory Selection window. After you select a directory, the window disappears and the full path name of the directory is displayed in the Header Pages Directory Path text box.

End Roll tab:

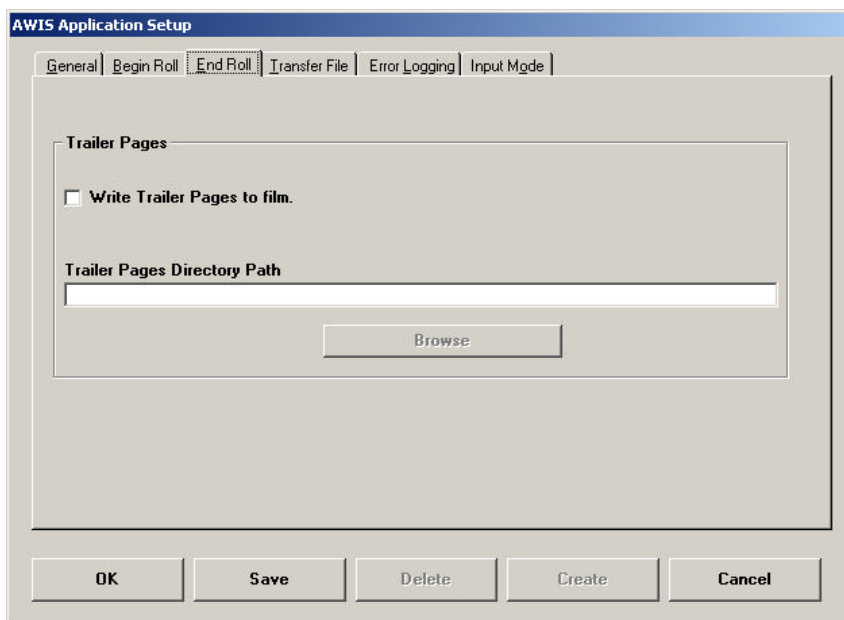

Write Trailer Pages to film — if checked, the trailer pages found in the Trailer Pages directory are written to film at the end of the roll after the last image designated via batch or list input.

Trailer Pages Directory Path — enter the path to a directory name where the trailer images reside or select **Browse** to display the Directory Selection window.

Browse — used to display the Directory Selection window. After you select a directory, the window disappears and the full pathname of the directory is displayed in the Trailer Pages Directory Path text box.

Application Setup — Transfer File tab

The Transfer File tab allows you to specify creation of Transfer files and configure the parameters associated with the Transfer files.

A Transfer file can be generated during the writing of images to film. It contains indexing information that can be uploaded to an image retrieval database. The location of each file is c:\Program Files\AWIS\Apps\ (Application Name)\ (Roll ID). The filename will be (Roll ID).xfr.

If a job spans more than one roll, the Transfer file for each subsequent roll will be created in the same directory as the Transfer file for the first roll. For example, when the transition from roll 1 to roll 2 occurs, the Transfer file <2.xfr> will be created in the directory <1>.

A standard or custom Transfer file can be generated. A standard Transfer file provides a cross-reference of input filename to Roll ID and image address. The page number within the input file is also listed. The fields are separated by tabs. See the 2-level example below, using page level reporting.

Filename	Page No. Within File	Roll ID	Image Address
c:\input\abc.tif	1	9999	FF.001.000
c:\input\abc.tif	2	9999	FF.001.001
c:\input\xyz.tif	1	9999	FF.002.000

Tabs



A custom Transfer file can be created via a user exit routine. This provides the capability to append additional data to the information in the standard Transfer file. For more information, see the *KODAK Archive Writer Interface Software, Integrator's Guide, A-61057*.

Following are descriptions of the fields on the Transfer File tab:

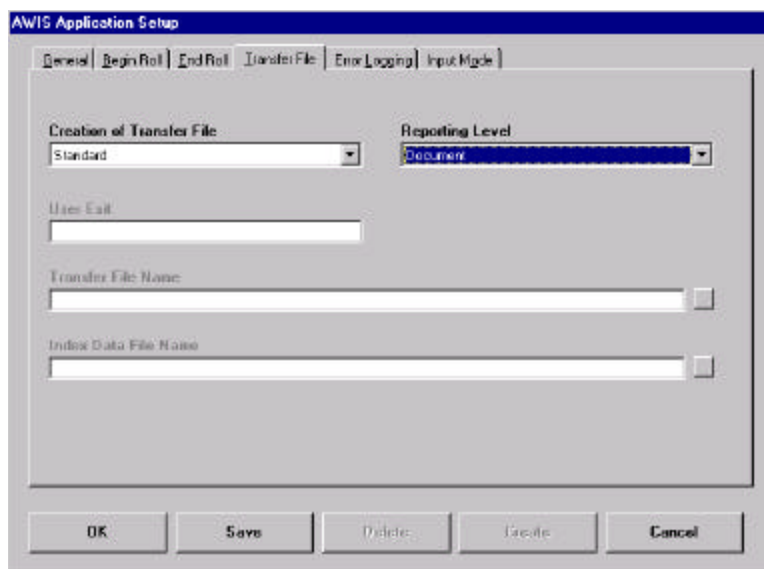

Creation of Transfer File — a drop-down list box provides options for creating the Transfer file:

- **None:** a Transfer file will not be created.
- **Standard:** the system-defined standard Transfer file will be created.
- **Custom:** enables the fields User Exit, Transfer File Name, and Index Data File Name.
 - **User Exit:** the name of the user exit. This value is required when specifying a custom Transfer file.
 - **Transfer File Name:** the path location of the custom Transfer file. If no value is specified, the file will be placed in the standard location.
 - **Index Data File Name:** the path location of the index data file containing information to be appended to the standard data in the custom Transfer file.

Reporting Level — depending on the index format, Transfer file entries can be done at the book, document or page level.

- **Page-level:** the Transfer file will contain index information for every image on the film. Applicable to any index format.
- **Document-level:** the Transfer file will contain index information for every image located in a 3-level and 2-level frame on the film. Applicable to 3-level and 2-level index format.
- **Book-level:** the Transfer file will contain index information for every image located in a 3-level frame on the film. Applicable to 3-level index format.

Application Setup — Error Logging tab

The Error Logging tab allows you to select the level and number of errors you want to post to the Error Log. The Error Log file can be accessed by clicking on the AWIS.log icon.

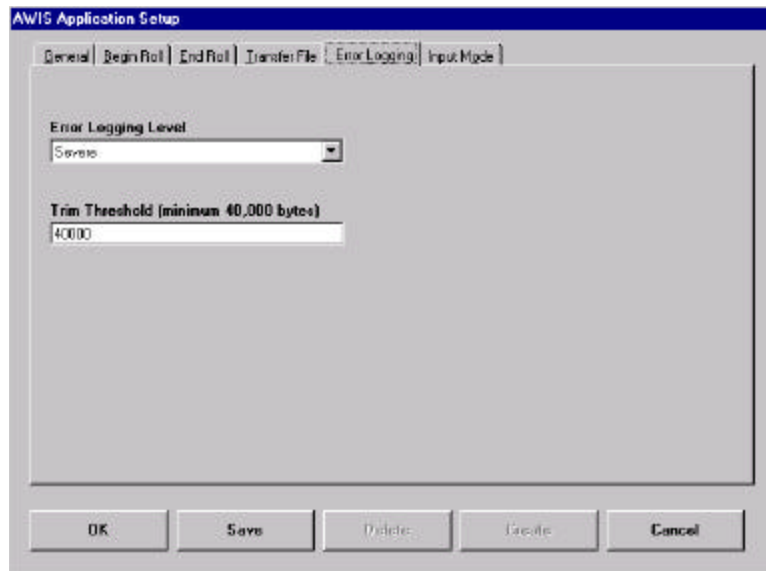

Error Logging Level — provides a drop-down list allowing you to select the level of errors you want to log.

- Diagnostic: logs all diagnostic messages, as well as informational, warning, and severe errors.
- Informational: logs all informational, warning and severe errors.
- Warning: logs all warning and severe errors.
- Severe: logs only severe errors. These errors are serious and will halt the system.

Trim Threshold — an entry in this field is required. Enter an integer between 40,000 and 9,999,999 bytes. The oldest errors in the Error Log file will be deleted in order to keep the size of the file less than this value.

Application Setup — Input Mode tab

AWIS reads image files from a disk drive (usually a drive that is shared on the network) and sends them to the Writer. Input modes allow you to sequence image files as desired on film. AWIS supports these input modes: List file, Batch and Poll.

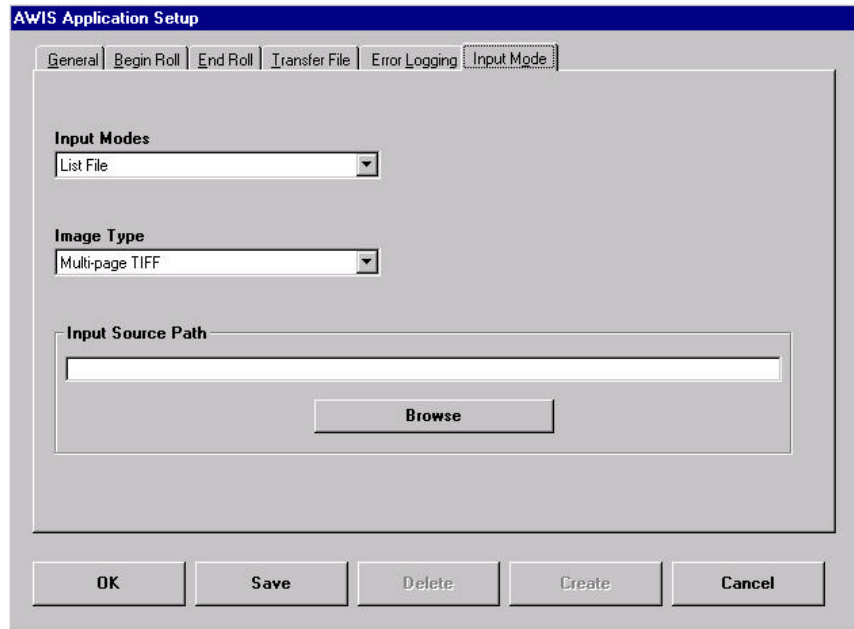

Input Mode — provides a drop-down list of supported Input Modes:

- **List File:** in this mode, the image files to be written to film must be listed in a file using full pathnames. Files are read and written to film in the same order as they appear in the List file. See Appendix A, *Input Modes* for more information.
- **Batch:** in this mode, image files are read from the directory specified in the Input Source Path field. See Appendix A, *Input Modes* for more information.
- **Poll:** in this mode, AWIS searches for a Poll file, which is created by some other means external to AWIS. See the section entitled, “File menu – Options” later in this chapter for more information.

Image Type — the image type of the input files must be specified as single- or multi-page TIFF. This value effects the layout of images on film, especially when the film mode is duplex. See Appendix A, *Input Modes* for more information.

- **Single-page TIFF:** file contains only one image. Images can be written to film separately using single-level index format, or grouped with other images and written using 2- or 3-level index format.
- **Multi-page TIFF:** file contains multiple images and each file can be considered a two-level group. Images can be written to film using single-level index format but the two-level grouping will be lost. Two-level index format allows the two-level grouping to be retained. The first image (simplex mode) or first two images (duplex mode) of each file will be written as level 2, and subsequent images will be written as level 1. This provides the capability to index and retrieve the entire multi-page file as a group. Multiple files can be grouped using three-level index format.

Input Source Path — the location of a directory if you selected a Batch or Poll input mode, or the location of the List file if you selected the List file input mode. A full pathname must be entered.

Browse — used to display the File Selection window for List file input, or Directory Selection window for Batch or poll input. After you select a file name or directory name, the window disappears and the full path is displayed in the Input Source Path text box. For more information, see “File Selection window” and “Directory Selection window” in Chapter 4.

Setting up an application

Applications are set up via AWIS Administration.

1. Select the AWIS Administration icon or **Start>Programs>AWIS Administration** to start the AWIS Administration function.
2. Select **File>Applications**. The AWIS Application Setup window is displayed.

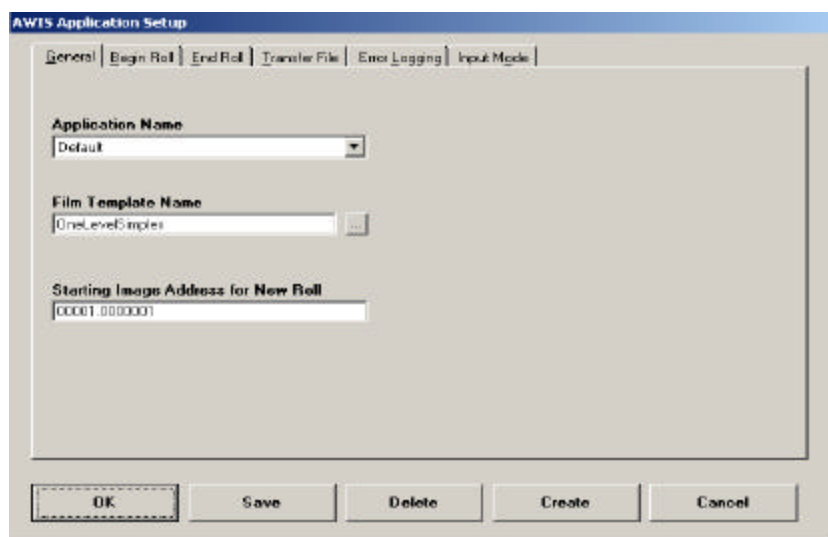

3. Select **Create**. The Create New Application dialog box is displayed.

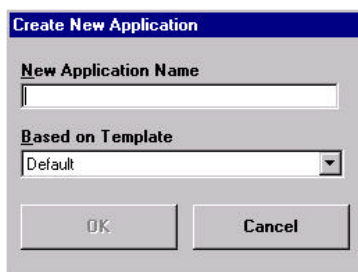

4. Enter the desired application name. The name can be a maximum of 25 characters, and include any keyboard character except an ‘ (apostrophe) and | (the pipe character).

5. Select a Based on Template from the drop-down list of existing applications and click **OK**. All parameters from the selected application are copied to the new application.
6. Change any of the copied parameters or set new parameters as necessary on the other tabs. The fields on these tabs are described earlier in this chapter.
7. Click **OK** to save the application and close the Application Setup window or **Save** to save the application and keep the Application Setup window displayed.

File menu — Archive Writers

Writer setup — General tab

When you select this option, the Archive Writer Setup window is displayed. This window contains a General and Version Numbers tab.

The General tab allows you to set up a new Writer or modify or delete an existing one.

The screenshot shows the 'Archive Writer Setup' dialog box with the 'General' tab selected. The dialog has a title bar and two tabs: 'General' and 'Version Numbers'. The 'General' tab contains the following fields and controls:

- Name:** A drop-down menu.
- Device Model:** A text field.
- IP Address:** A text field.
- Exposure:** A numeric input field with up/down arrows, and two buttons: 'Darken (maximum 50)' and 'Lighten (minimum 5)'.
- Power Down Interval in minutes:** A numeric input field with up/down arrows, and two buttons: 'Increase (Maximum 10-999)' and 'Decrease (Minimum 0)'.
- File Transfer Interval in seconds:** A numeric input field with up/down arrows, and two buttons: 'Increase (maximum 600)' and 'Decrease (minimum 1)'.

At the bottom of the dialog are five buttons: 'OK', 'Save', 'Delete', 'Create', and 'Cancel'.

Name — provides a drop-down list of Writers currently set up in the system. Select an existing Writer from the list or if you want to set up a new Writer, click **Create** to display the Create Archive Writer dialog box. See the section entitled, “Setting up a Writer” later in this chapter for procedures.

The following fields will contain a value only when a valid value is specified in the name field.

Device Model — memory configuration of the Writer. Large or Small is displayed; this value cannot be changed.

IP Address — the static IP address of the Writer is displayed; this value cannot be changed.

Exposure — enter/select an exposure value from 5 to 50 to lighten or darken the images on film. The default value is 14.

Power Down Interval in minutes — defines how many minutes must pass without activity before the status display on the Writer goes into power-saving mode. Value Range 00, 10 to 999 minutes. The disable value is 0.

File Transfer Interval in seconds — enter/select the number of seconds (1 to 600 seconds) allowed for a file transfer between AWIS and the Writer (any command file, images file, response file, status file). This value should be large enough to ensure the file transfer does not hang and there is adequate time for the transfer. The default is 60 seconds.

Writer setup — Version Numbers tab

When the Name field on the General tab contains a value, the Version Numbers tab displays the current version information for the Controller, DCSM Version, WRIB version, Film Drive, and Operator Interface. The information on this tab is for viewing purposes only and cannot be changed.

The screenshot shows a dialog box titled "Archive Writer Setup: [shale-fw2]". It has two tabs: "General" and "Version Numbers", with "Version Numbers" selected. The dialog contains five text input fields for version information:

Field Name	Value
Controller	V1.2.4
Film Drive	V8.03
DCSM Version	V004
Operator Interface	V01.02.00
WRIB Version	V001

At the bottom of the dialog, there are five buttons: "OK", "Save", "Delete", "Create", and "Cancel".

Setting up a Writer

Writers are set up via AWIS Administration. To set up a Writer:

1. Select the AWIS Administration icon or **Start>Programs>AWIS Administration** to start the AWIS Administration function.
2. Select **File>Archive Writers**. The Archive Writer Setup window is displayed:

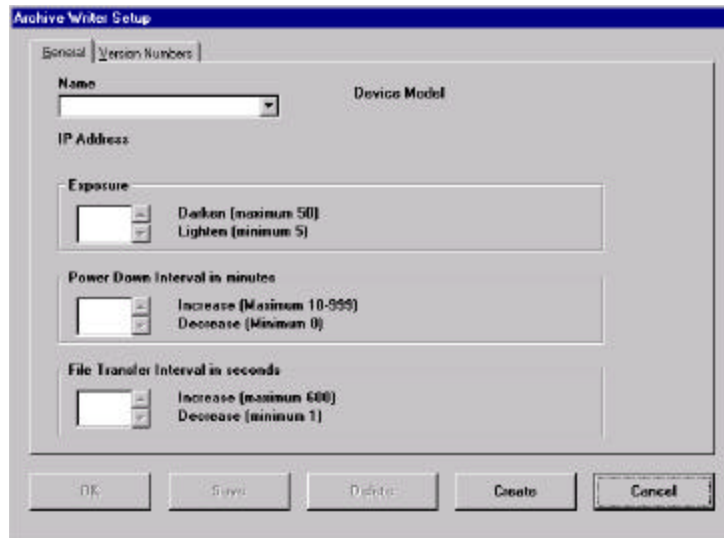

3. Click **Create**. The Create Archive Writer dialog box is displayed:

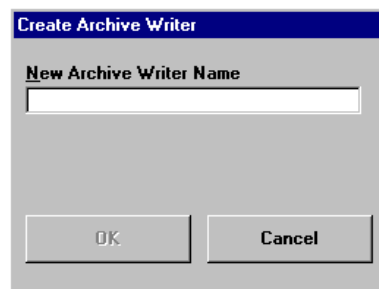

4. Enter a Writer name. The name can be a maximum of 25 characters, and include any keyboard character except an ' (apostrophe) and | (the pipe character).
5. Click **OK**. The Create Archive Writer dialog box is redisplayed prompting you for an IP address.
6. Enter the static IP address that was defined for the Writer during installation of the Writer, and click **OK**. If you are not sure of the correct value, see your System Administrator.
7. The Archive Writer Setup window is redisplayed with current values obtained from the Writer. If desired, select new Exposure, Power Down Interval, or Transfer File Interval values.
8. Click **OK** or **Save**.

File menu — Film templates

When you select **Film Templates** from the File menu, the Film Template Server window is displayed with the following tabs: General, Film Physical Attributes, Image Addressing, Frame Annotation and IMC. Each tab allows you to set up an aspect of the film template.

Use the Film Templates window to set up a film template for each kind of roll you create.

Film templates — General tab

Use the General tab to define a new film template or select and modify an existing film template.

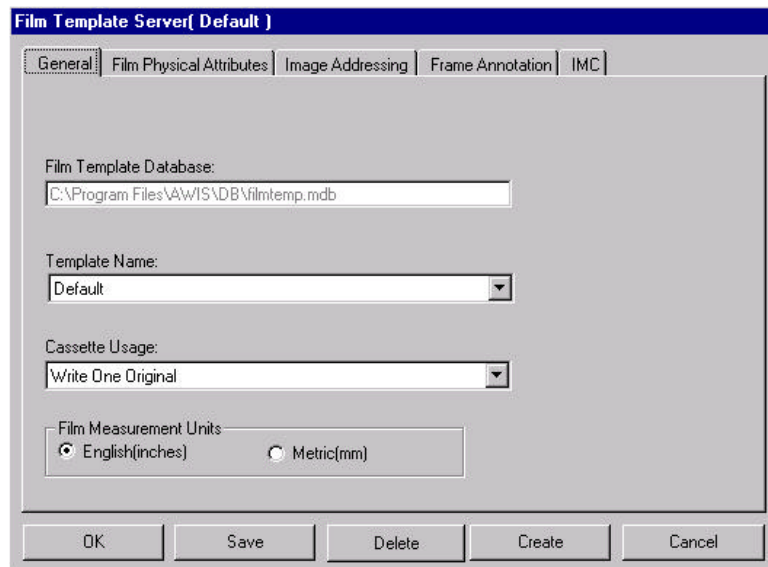

The screenshot shows the 'Film Template Server (Default)' dialog box with the 'General' tab selected. The dialog has five tabs: 'General', 'Film Physical Attributes', 'Image Addressing', 'Frame Annotation', and 'IMC'. The 'General' tab contains the following fields and controls:

- Film Template Database:** A text field containing the path 'C:\Program Files\AWIS\DB\filmtemp.mdb'.
- Template Name:** A drop-down menu currently showing 'Default'.
- Cassette Usage:** A drop-down menu currently showing 'Write One Original'.
- Film Measurement Units:** A group box containing two radio buttons: 'English(inches)' (which is selected) and 'Metric(mm)'.

At the bottom of the dialog are five buttons: 'OK', 'Save', 'Delete', 'Create', and 'Cancel'.

Film Template Database — displays the path to the film template database. This field cannot be changed.

Template Name — select an existing template from the drop-down film template database list, or you can create a new film template by selecting **Create**. For procedures on creating a film template, see the section entitled, “Creating a film template” later in this chapter.

Cassette Usage — select the number of cassettes to be written. You can select **Write One Original** or **Write Two Originals** to write two duplicates simultaneously.

Film Measurement Units — select the measurement system you want to use when advancing film, applying a leader, etc. Select either English (inches) or Metric (millimeters). The default is English.

NOTE: Interdocument gap will always be measured in millimeters, regardless of this value.

Film Templates — Film Physical Attributes tab

The Film Physical Attributes tab allows you to enter parameters that determine image size, spacing and location on film. Image polarity is also specified.

The screenshot shows the 'Film Physical Attributes' tab of the 'Film Template Server (Default)' dialog. It contains several settings:

- Film Mode:** A dropdown menu set to 'Simplex'.
- Film Leader Length:** A text box with '36' and 'in.' next to it.
- Film Advance Length:** A text box with '1' and 'in.' next to it.
- InterDocument Gap:** A text box with '0.7' and 'mm.' next to it.
- Scaling:** A dropdown menu set to 'Automatic'.
- Reduction Ratio:** A dropdown menu set to '24X reduction'.
- Scaling Factor:** A text box that is currently empty.
- Image Polarity:** A group box containing two radio buttons: 'Positive' (which is selected) and 'Negative'.

At the bottom of the dialog are five buttons: 'OK', 'Save', 'Delete', 'Create', and 'Cancel'.

Film Mode — two film modes are supported: Simplex and Duplex.

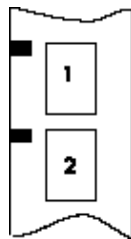

Simplex – Each frame contains only one image.

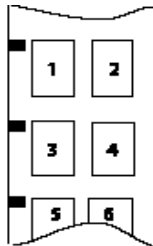

Duplex – A frame can contain one or two images. Images are written alternately to the A and B channels. The number of images in any individual frame depends on the index format and image level. If the index format is single-level, each frame will contain two images. If the index format is 2-level or 3-level, the B channel will be left blank in any frame where a higher-level image follows the A channel image.

NOTE: With optical film capture devices, Duplex is associated with front and back, since the fronts and backs of sheets of paper are directly imaged to film. With the Writer, the concept of front and back is not applicable since the input is electronic files, which do not contain fronts and backs, but rather are identified as single-page or multi-page.

For more information about film layout relative to film mode and input file type, see Appendix A, *Input Modes*.

Film Leader Length — enter the desired length of the film leader (from 914 to 3048 millimeters/36 to 120 inches). The appropriate value is determined by the requirements of the equipment that will be used for subsequent retrieval of images. The default is 914 millimeters/36 inches.

Film Advance Length — enter the desired length of film to advance between jobs (from 26 to 2515 millimeters/1 to 99 inches). The default is 26 millimeters/1 inch.

InterDocument Gap — enter a value between 0.6 mm and 5.0 mm to set the distance between images on film. The default is 0.7 mm. This value will always be measured in millimeters regardless of the Film Measurement Units.

Scaling and Reduction Ratio — The Writer can archive documents at 1/20 (20X) to 1/99 (99X) of their hard copy size. Reductions are achieved through image file scaling. See the illustration entitled, “Examples of scaling and image orientation on film” at the end of this section.

Scaling — There are two choices: **No Scaling** or **Automatic**.

- **No Scaling:** Image size on the film is dependent on the digital resolution (dpi) of the image file.

The maximum page widths and lengths accommodated by the Writer are listed below for No Scaling.

Image Resolution dpi	Effective Reduction Ratio	Maximum Width Simplex	Maximum Width Duplex	Maximum Length
100	77X	977 mm 38.5 in.	482 mm 19.0 in.	1740 mm 68.5 in.
200	39X	490 mm 19.3 in.	241 mm 9.5 in.	871 mm 34.3 in.
300	26X	325 mm 12.8 in.	160 mm 6.3 in.	579 mm 22.8 in.
400	19X	246 mm 9.7 in.	121 mm 4.8 in.	436 mm 17.2 in.
600	13X	162 mm 6.4 in.	78 mm 3.1 in.	289 mm 11.4 in.

- **Automatic:** image size on the film is independent of the digital resolution (dpi) of the image file. Automatic scaling to a desired reduction is recommended for most applications. Reduction Ratio is enabled when scaling is Automatic.

Standard microfilm reductions are recommended:

- Simplex: 24X, 28X, 32X, 40X
- Duplex: 40X, 50X

The maximum page widths and lengths accommodated by the Writer are listed below for standard reductions.

Standard Reduction Ratio	Maximum Width Simplex	Maximum Width Duplex	Maximum Length
24X	302 mm 11.9 in.	149 mm 5.9 in.	538 mm 21.2 in.
32X	403 mm 15.9 in.	198 mm 7.8 in.	718 mm 28.3 in.
40X	490 mm 19.3 in.	241 mm 9.5 in.	871 mm 34.3 in.
50X	632 mm 24.9 in.	312 mm 12.3 in.	1125 mm 44.3 in.

Reduction Ratio — select a predefined option (24X, 40X, 50X) or Custom. If you select **Custom**, the Scaling Factor option becomes enabled.

Scaling Factor — enter the scaling factor as a number from 0 to 99 (i.e., 32 would be a 32X reduction ratio).

NOTE: Reducing more than 60X may produce undesirable image quality and is not recommended.

Image Polarity — The Writer has the ability to write images in a positive or negative image polarity. Positive is black characters on a clear background. Negative is clear characters on a black background.

Retrieval considerations dictate polarity requirements.

- **Positive**

- Retrieval equipment does not need the capability of inverting images for display.
- Lack of definitive borders may occur in some images on film. An image border can be placed around positive images during writing to film, to delineate the edges of the image.

- **Negative**

- The default in traditional microfilm retrieval equipment.
- Minimizes the impact of dust or other contamination when displaying an image during retrieval.

Examples of scaling and image orientation on film

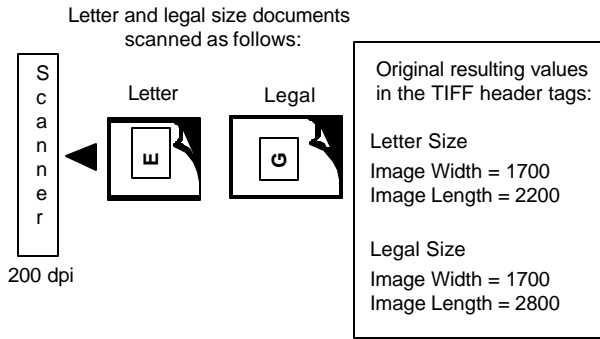

These scanned images will print to film as follows:

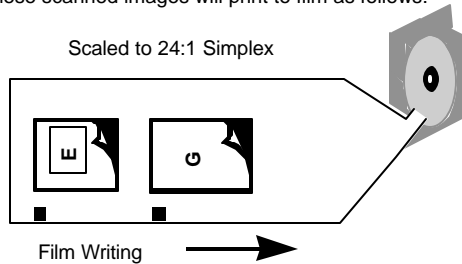
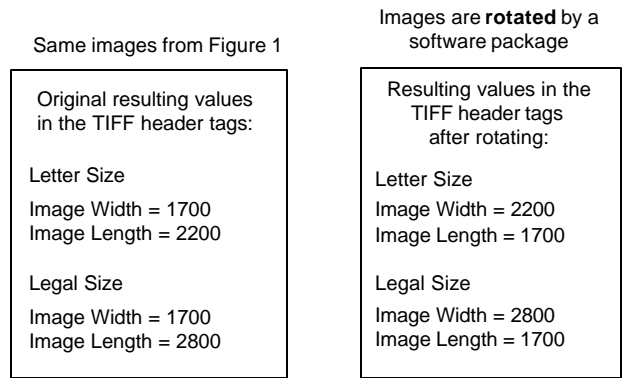

Figure 1



These scanned images will print to film as follows:

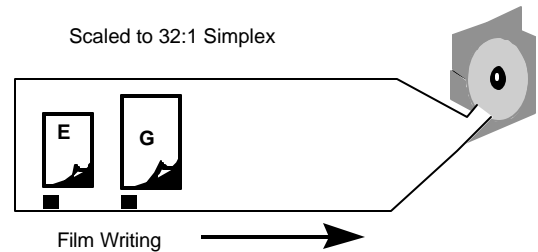
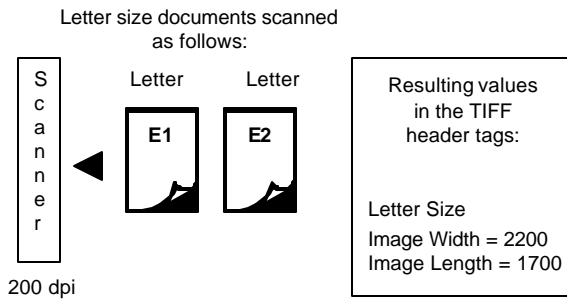

Figure 2



These scanned images will print to film as follows:

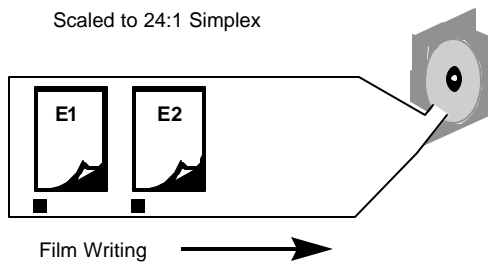
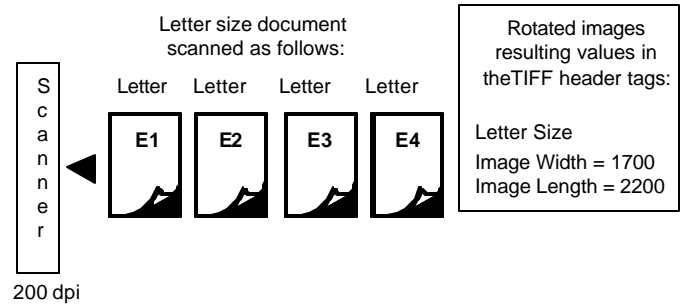

Figure 3



These scanned images will print to film as follows:

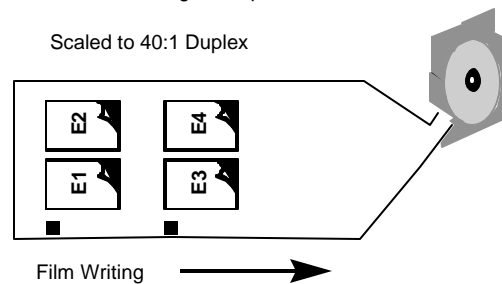

Figure 4

NOTE: If rotation is desired, the images must be rotated by a third-party software product prior to passing the images to AWIS.

Film Templates — Image Addressing tab

The Image Addressing tab contains parameters for controlling how image addresses are created, and at what level each image will be written to film. These values determine what will be accepted as a valid starting image address for a new roll, in application setup.

See Appendix D, *Index Format, Image Addresses and Image Marks* for detailed information.

The screenshot shows the 'Image Addressing' tab of the 'Film Template Server (Default)' dialog. It features a tabbed interface with 'Image Addressing' selected. The 'Index Formats' section has a dropdown menu set to 'Single Level'. The 'Field Width' section includes a 'Fixed' field with the value '5', and three rows for 'Level 3', 'Level 2', and 'Level 1', each with a text input field containing '0', '0', and '7' respectively. The 'Level 0' label is present but lacks an input field. The 'Level Rule' section has four dropdown menus set to 'Level 0', 'Level 0', 'Level 1', and 'Level 1'. A 'Set default' checkbox is located at the bottom right of the settings area. At the bottom of the dialog are buttons for 'OK', 'Save', 'Delete', 'Create', and 'Cancel'.

Index Formats — a drop-down list of formats that can be used for the images: No Indexing, Single Level, Two Level, and Three Level. This value effects the hierarchal grouping of images on the film.

Field Width — the maximum number of characters needed in that segment to accommodate the largest value that will be assigned during the writing of images to film. For example, on a single-level roll with 10,000 images, the Level 1 field width must be at least 5. The total for all enabled segments cannot exceed 12 but the maximum for each individual segment is 9.

NOTE: Level 0 images are not assigned an image address.

An image address can have up to four segments depending on the Index Format selected.

A field width must be specified for each enabled segment, except Fixed which is optional. If you select Single Level index format, Level 1 field width is enabled. If you select Two Level index format, Level 1 and Level 2 are enabled. If you select Three Level index format, Level 1, Level 2 and Level 3 are enabled.

Level Rule — the default level rule may be changed but it is not recommended since they provide the most efficient and predictable results. For more information about image levels, see Appendix D, *Index Formats, Image Addresses and Image Marks*.

Set default — returns level rules to the original recommended settings.

Film Templates — Frame Annotation tab

The Frame Annotation tab contains parameters for optionally writing the image address and reduction ratio on the frame in human-readable characters placed between the image mark and the actual image.

Example 1: Simplex, 24X reduction with frame annotation enabled.

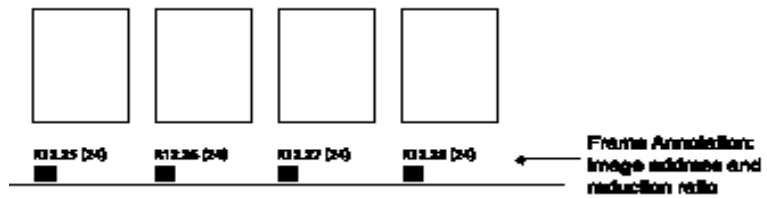

Example 2: Duplex; 24X reduction with frame annotation enabled.

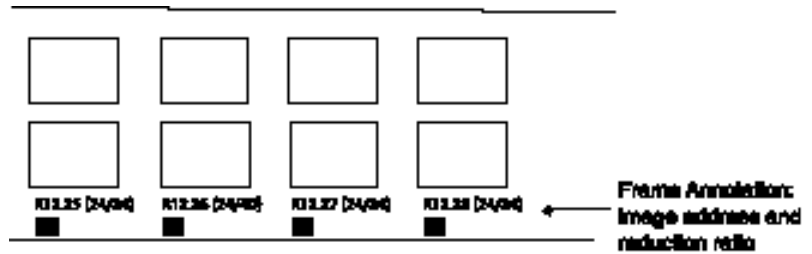

Following are descriptions of the fields on the Frame Annotation tab:

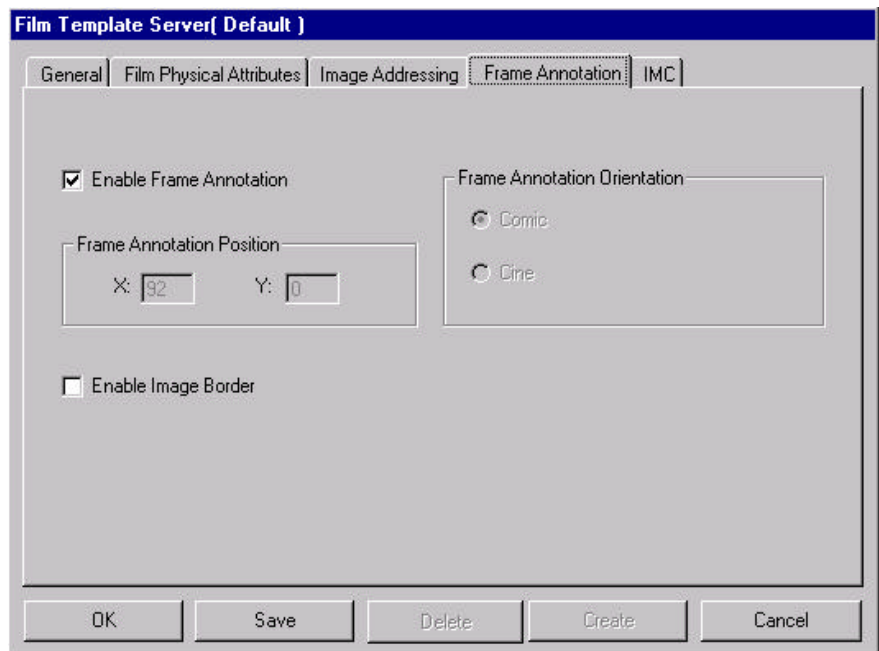

Enable Frame Annotation — allows you to write annotation information on film.

Frame Annotation Position — not supported in Release 3.1.

Enable Image Border — when this option is enabled, a thin border will be placed around all images. Placing a border around images helps identify the boundaries on positive polarity images.

Frame Annotation Orientation — not supported in Release 3.1.

Film Templates — IMC tab

The IMC tab controls the type of IMC (Image Management Code) that will be written to the film preceding the images for every job that uses a film template with IMC enabled.

IMC capability includes lead-end and preset coding, which provide automatic setup parameters for the image retrieval device.

Enable IMC — provides a drop-down list that allows selection of IMC as implemented for various Kodak optical film capture devices. This facilitates integration of the Writer in environments where the retrieval devices support current Kodak IMC. The options are: Disable IMC, Enable IL70 code, Enable RIM2000 code, or Random Batch. The default is Disable IMC.

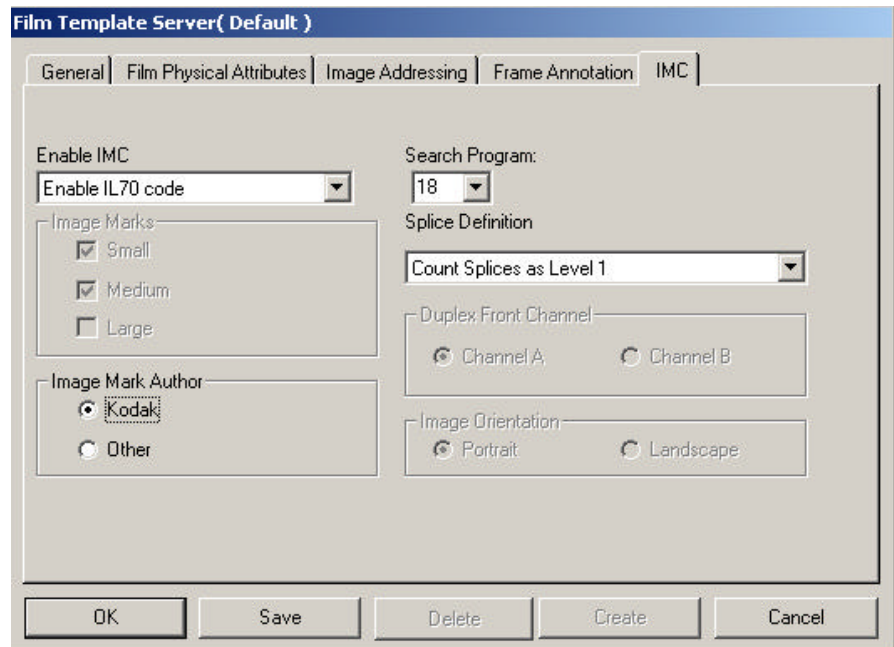

Image Marks — not supported in Release 3.1.

Image Mark Author — determines the alignment of the image mark relative to the image, and the physical dimensions of each image mark size. Select either **Kodak** (default) or **Other**. Kodak image marks have the leading edge of the image mark aligned with the leading edge of the image.

Search Program — if IMC is enabled, a search program must be specified. The search program tells the retrieval device which film channel(s) (A and/or B) contain image marks, the image mark sizes present on the film, and the image level represented by each image mark size. This allows the retrieval device to locate and count the image marks according to your needs. There are 31 search programs available for use when writing images to film but the Writer does not support creation of film for all of these. The drop-down box contains the search programs that are supported by the Writer.

The table below provides information about the supported search programs, to assist you in determining which program is appropriate based upon the film to be written and the retrieval needs.

NOTE: The Search Program field drop-down box contains a value of “1”, but the table does not. Search program 1 is used for odometer-indexed film, which has special retrieval requirements and does not contain image marks.

Index Format	Image Mark Location	Image Mark Sizes	How image marks will be counted during retrieval	Search Program
Single-level	Channel A	Small	Count small image marks as level 1 images.	3
2-level	Channel A	Small Medium	Count small image marks as level 1 images, and medium image marks as level 2 images.	10
3-level	Channel A	Small Medium Large	Count small image marks as level 1 images, and both medium and large image marks as level 2 images.	12
3-level	Channel A	Small Medium Large	Count small image marks as level 1 images, medium image marks as level 2 images, and large image marks as level 3 images.	18
Any	Channel A	Any/All	Count all image marks as level 1 images.	7

Splice Definition — specifies how film splices will be counted during retrieval. The drop-down list provides these splice definitions: Ignore Splices (default), Count splices as Level 1, Count splices as Level 2, or Count splices as Level 3.

Duplex Front Channel — cannot be changed. The Writer supports image mark creation in the A channel only.

Image Orientation — cannot be changed. For more information about image orientation, see “Examples of scaling and image orientation on film” earlier in this section.

Creating a film template

Film templates are created via AWIS Administration. To create a film template follow the procedures below.

1. Select the AWIS Administration icon or **Start>Programs>AWIS Administration** to start the AWIS Administration function.
2. Select **File>Film Templates**. The “Default” template appears in the Template Name text box.

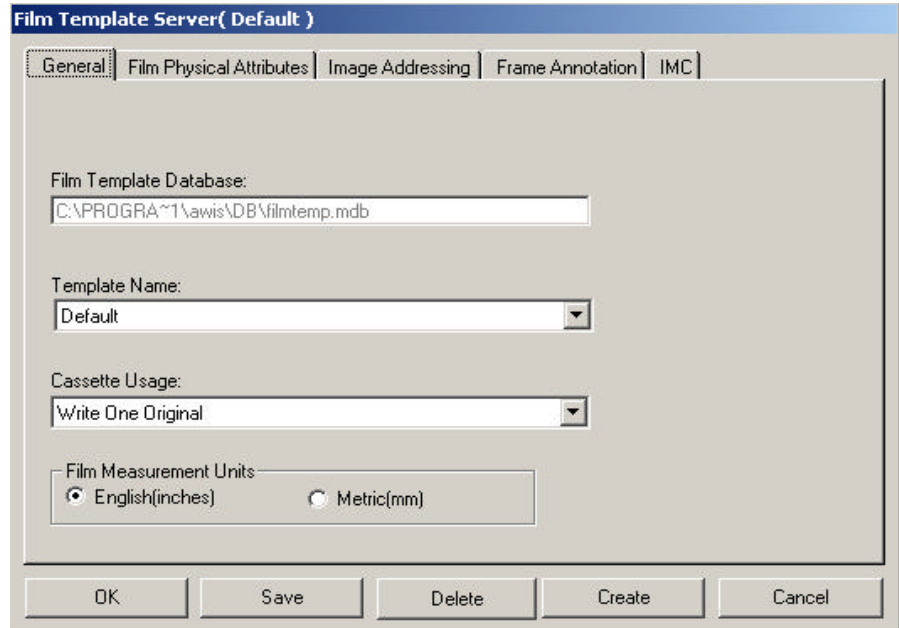

3. Click **Create**. The Create Template dialog box is displayed.

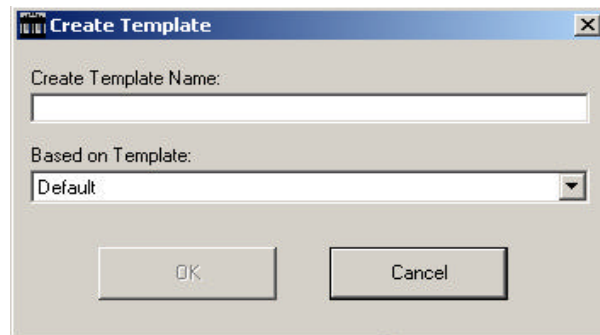

4. Enter the name of a new template and select an existing film template that the new template will be based on and click **OK**. The Film Template Server window is redisplayed with the new template as the current template. All parameters from the “based on template” are copied to the new film template.
5. Change any of the parameter values on the tabs as necessary.
6. Click **OK** to save the template and close the window or **Save** to save the template and keep the window displayed.

File menu — Options

When you select **Options** from the File menu, the Options window is displayed. This window contains the Polling and Advanced tabs.

Options — Polling tab

The Polling tab allows you to configure the parameters associated with Poll mode. In Poll mode, AWIS searches for a Poll file, which is created by some other means external to AWIS and placed in a polling directory that is specified during application setup. When the Writer is integrated with a scanner, Poll mode facilitates simultaneous scanning and filming of images, without the need of an intermediate, manual batching step. After all images indicated by a Poll file are processed, the Poll file is deleted from the polling directory, and polling resumes.

Following are descriptions of the fields on the Polling tab:

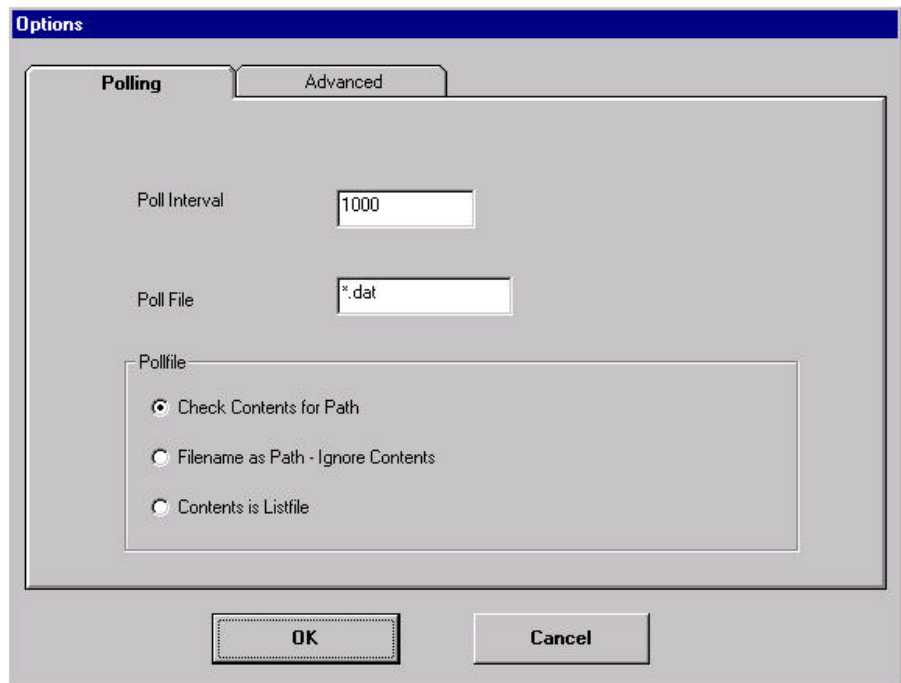

The screenshot shows the 'Options' dialog box with the 'Polling' tab selected. The 'Advanced' tab is also visible. The 'Poll Interval' field contains the value '1000'. The 'Poll File' field contains the value '*.dat'. The 'Pollfile' section has three radio buttons: 'Check Contents for Path' (selected), 'Filename as Path - Ignore Contents', and 'Contents is Listfile'. At the bottom, there are 'OK' and 'Cancel' buttons.

Poll Interval — enter the amount of time, in milliseconds, that the AWIS application will wait between searches for a Poll file to be processed. The default is 3000.

Poll File — enter the name of the file which AWIS will search for. If various files will be used, wild cards (Windows file system wildcards are acceptable) are allowed in this field. The default is *.dat; this will allow processing of any file, placed in the polling directory, that ends with a .dat extension.

Pollfile — select the method by which the Poll file should be processed.

- **Check Contents for Path:** a Poll file may be empty, or contain a full pathname to either an input List file or batch directory. If the Poll file is empty, the Poll file is processed the same as the Filename as Path-Ignore Contents method, and must comply with the requirements of that method. If the Poll file contains a full pathname, the specified List file or batch directory is processed according to the application setup and film template parameters.
- **Filename as Path - Ignore Contents:** an empty Poll file can be used to specify an input batch directory. The Poll file name must be the same as the batch directory name, and the Poll file must be placed in the same home directory where the input batch directory is located.
- **Contents is Listfile:** a List file can be used as a Poll file. This provides a method for automatically submitting List files which will then be automatically processed. When processing is complete, the List file is removed from the polling directory and copied to the same directory as the Transfer file for the job.

Options — Advanced tab

The parameters on the Advanced tab are set to optimize performance. During installation the values of these parameters are set to the default. For most applications, the defaults are sufficient and should only be changed to address a specific issue and after a thorough review of the following information.

The screenshot shows a dialog box titled "Options" with two tabs: "Polling" and "Advanced". The "Advanced" tab is selected. The dialog contains the following fields and values:

Field	Value
Number of Commands	4
Transaction Timeout	300
Number of Files	4
File Retry Count	40
Retry Delay	2000

At the bottom of the dialog are two buttons: "OK" and "Cancel".

Following is a description of the fields on the Advanced tab:

Number of Commands — The maximum number of print commands that can be active simultaneously. The maximum value depends on the Number of Files value since the product of the Number of Files and Number of Commands, cannot exceed 120. Default 8.

Number of Files — The maximum number of image files that a print command can contain. The maximum value depends on the Number of Commands value. The product of the Number of Files and Number of Commands cannot exceed 120. Default 8.

The Number of Commands and Number of Files work together to maximize command and image throughput by minimizing the amount of time the Writer will have to wait for print commands. This is accomplished by ensuring that there are at least two commands active at once: the command currently being processed by the Writer, and the command on the Writer disk waiting to be processed. For AWIS, this results in four active commands:

- one command being built and copied to the Writer
- one response received from the Writer when a command is completed
- the two commands on the Writer (one waiting to be processed and one being processed)

This implies that the minimum value for Number of Commands is 4. This value is usually left at the default value of 8, which allows a few extra commands available if needed.

Image file size and Writer disk size must be considered when determining the appropriate value to enter for the Number of Files. To determine this value, use the following formula as a guideline:

$$\left[\frac{\text{Maximum available Writer disk space}}{\text{Number of Commands}} \right] \div \text{average Image file size, rounded down}$$

For example:

$$(1100 \div 8) \div 10 = 13$$

File Retry Count — The number of times AWIS attempts to copy an image file to the Writer before giving up and signaling an error. This value is used in conjunction with the Retry Delay value to determine the total amount of time AWIS will wait for the Writer to process existing commands and image files and make space available on its disk. Default: 20.

Retry Delay — The amount of time (in milliseconds) to wait before attempting to copy an image file to the Writer again. This value is used in conjunction with the File Retry Count value to determine the total amount of time AWIS will wait for the Writer to process existing commands and image files and make space available on its disk. Default: 2000.

The combination of the default Retry Delay (2000 milliseconds) and default File Retry Count (20 attempts) gives the Writer 40 seconds to finish processing commands and image files and make space for new commands and files. For most applications this is sufficient; however, when processing very large image files (greater than 750K), 40 seconds may not be enough. In this case, the File Retry Count needs to be increased. Increase the value in increments of 5 until the largest file can be processed without a 3034 error occurring. It is important not to set this to some arbitrarily large value, because in the event of an error, this can increase the time it takes to report the error. Setting File Retry Count to a value too small causes the 3034 error to occur more frequently.

Generally, the Retry Delay should be kept at the default. Decreasing this value causes the copy requests to become more frequent but also increases network traffic. Increasing this value may cause a loss of throughput.

The product of Retry Delay and File Retry Count must be a time interval larger than the time it takes to process the largest image file.

Transaction Timeout —The maximum time (in seconds) AWIS will wait for the Writer to process a command and send a response. Default: 180. This value may only need to be changed when the processing of a print command and its associated images takes longer than 90 seconds.

The value of this parameter should always be about 30 seconds larger than the time specified by the Retry Delay and File Retry Count parameters.

NOTE: If network performance seems to be an issue, the following values may optimize performance: 4, 4, 40, 2000, 300 respectively.

File menu — Exit

Select **File>Exit** to close AWIS Administration.

Purge menu

When you select **Purge** from the menu bar, the Purge Job window is displayed. Use this window to remove any or all of the following from the system: job data, input List files, Transfer files, and image files.

NOTE: Only verified jobs and their associated files can be deleted using the Purge function. See *Chapter 4, "File Menu — Verify Jobs"* for more information.

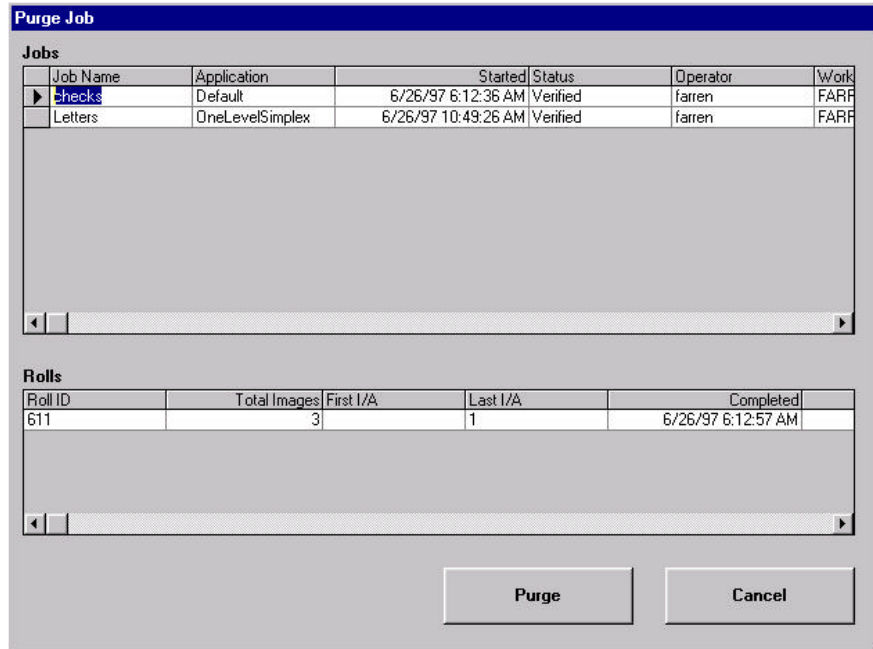

Jobs — displays information about the jobs that have been verified, including the job name, the application used to run the job, the date and time that the job was started, the fact that the job was verified, the login ID of the operator who verified the job, the workstation ID of the host PC from which the job was run, the Roll ID assigned to the film when the job was run, and a status code of 4 (the code for “verified”).

Rolls — displays information for the roll of film associated with the selected job, including the Roll ID assigned to the film when the job was run, the total number of images written to film using that job, the first and last image addresses assigned using that job, the date and time that the job was completed, and the roll number indicating whether the job required more than one roll of film.

NOTE: The columns and rows on the Purge Job window can be resized by positioning the mouse on the column or row lines in the headings and moving the mouse, while holding down the left mouse button, to the desired position.

Purging jobs and /or associated files from the system

To remove job data and/or associated files from the system:

1. Select the AWIS Administration icon or **Start>Programs>AWIS Administration** to start the AWIS Administration function.
2. Select **Purge** from the main menu. This will be available only if there are jobs with a status of *Verified* in the system.
3. Select the desired job from the Jobs table.

NOTE: Even though multiple jobs can be selected at one time, the system will only perform actions on the first job selected.

4. Click **Purge**. The Purge Job [jobname] window is displayed.

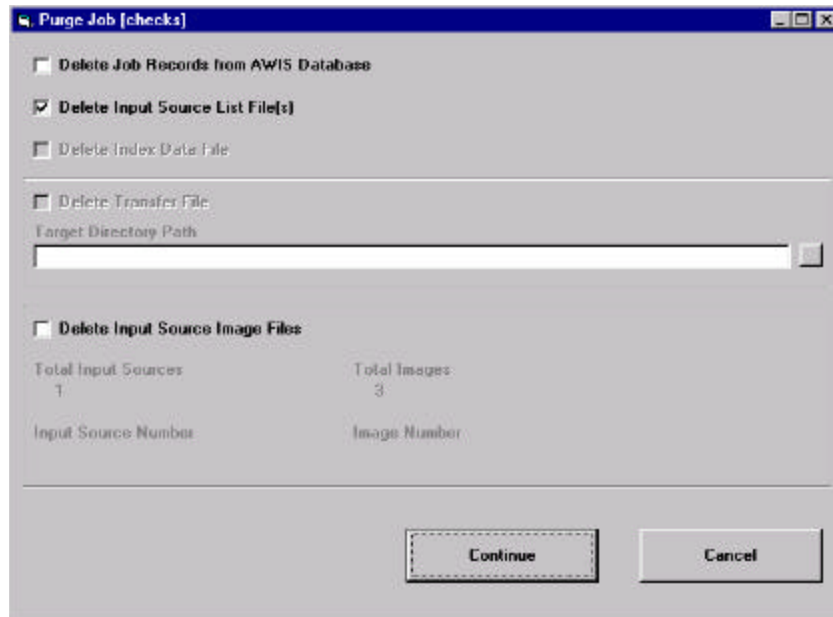

5. Select one or more of the following options:
 - **Delete Job Records from AWIS Database:** allows the Roll ID associated with the job to be re-used, if necessary, by the application used to run the job. All data pertaining to the selected job will be deleted from the awis.mdb database and the job will be removed from the Jobs table in the Purge Job window. If this option is used alone, the capability to use this purge function, to remove associated files for the job from the system, will be lost.
 - **Delete Input Source List File(s):** this option is enabled only if a List file was used to submit images for the job, and the file was not previously deleted using this purge option. This option may be used alone to delete just the input List file and not remove the job from the Jobs table.
 - **Delete Index Data File:** this option is enabled only if a customer Transfer file was generated using an index data file. This option may be used alone to delete just the index data file and not remove the job from the Jobs table.
 - **Delete Transfer File:** this option is enabled only if a Transfer file was created. This option may be used alone to delete just the Transfer file and not remove the job from the Jobs table.

- **Target Directory Path:** this option is enabled and a value must be specified only if the Delete Job Records option is selected and the Delete Transfer file option is enabled but not selected. This option provides the capability to move the Transfer file rather than delete it. This field must contain a valid path to a directory where the Transfer file will be moved. The ... button can be used to open the Directory Selection dialog box and navigate to the desired directory, or a path can be typed directly into the Target Directory Path field.
- **Delete Input Source Image Files** — this option can be used to delete the source image files when a List file was used to submit images for the job, and the List file is still on the system. The accompanying fields are informational only.

Reports menu

When you select **Reports** from the menu bar, the Print Reports window is displayed. Use this window to print and/or export a report of current AWIS jobs with a status of Complete or Verified. The report format cannot be changed but the report content can be customized. The report provides information regarding the jobs run and rolls of film written for each application defined via application setup. See the sample report at the end of this section.

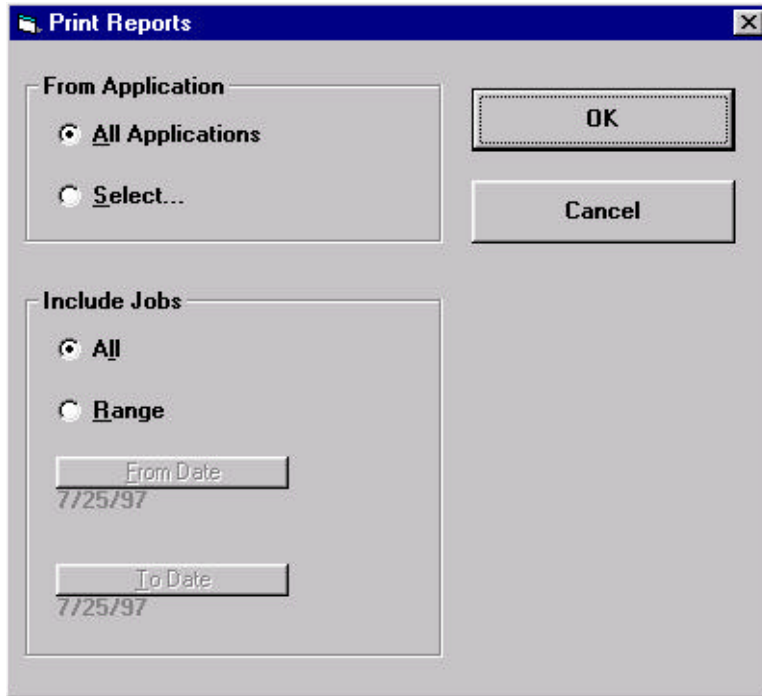

The screenshot shows a dialog box titled "Print Reports" with a close button (X) in the top right corner. The dialog is divided into two main sections. The first section, "From Application", contains two radio buttons: "All Applications" (which is selected) and "Select...". The second section, "Include Jobs", contains two radio buttons: "All" (which is selected) and "Range". Below the "Range" radio button are two date input fields. The first field is labeled "From Date" and contains the text "7/25/97". The second field is labeled "To Date" and also contains the text "7/25/97". To the right of the "From Application" section are two buttons: "OK" and "Cancel".

From Application — determines whether the report includes information about all applications or only selected applications.

Include Jobs — determines whether the report will include all jobs for each specified application or only those that fall within a range of dates.

Printing and exporting reports

To print and/or export a report:

1. Select **Reports** from the AWIS Administration main menu. The Print Reports window will be displayed.

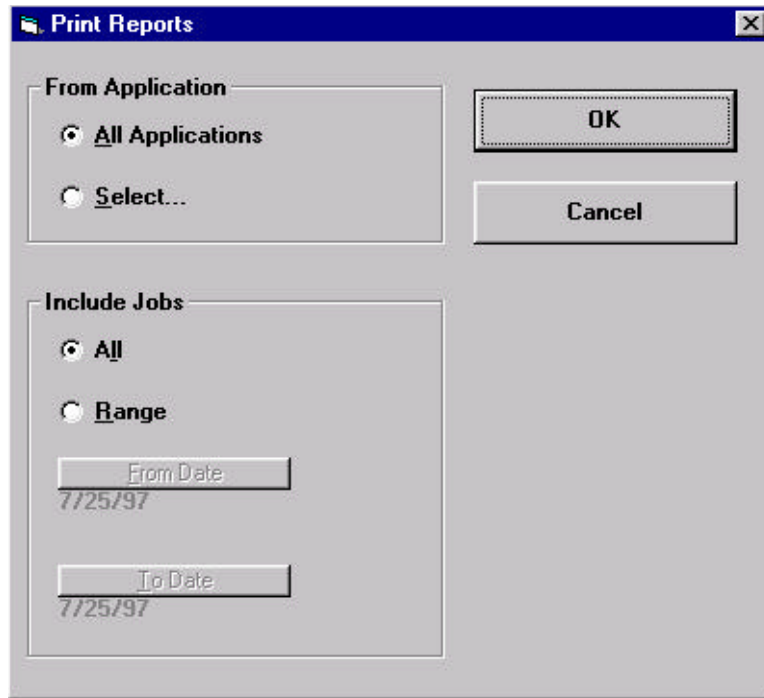

2. **From Application:** Select either **All Applications** or **Select...** based upon what applications you want to include in the report. If you choose **Select...**, the Report Application Selection window is displayed.

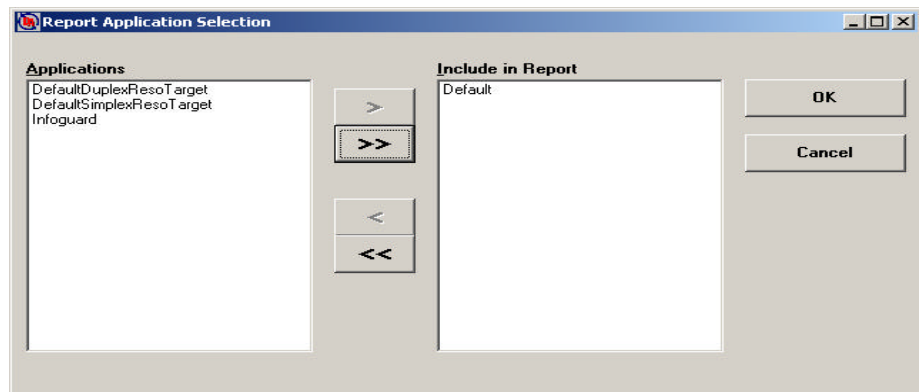

3. Select an application from the Applications list, then click the > button to add the application to the Include in Report list. Repeat for all desired applications. If most applications are to be included, use the >> button to add all applications to the Include in Report list, then select and remove the unwanted applications with the < button.
4. Click **OK**. The Print Reports window is redisplayed.

5. **Include Jobs:** Select either **All** or **Range** based upon the jobs you want included in the report for each selected application. If you select **Range**, the From Date and To Date fields are enabled and must be specified. A small calendar is displayed, which allows you to easily select the desired day, month and year.
6. Click **OK** in the Print Reports window. The Preview window is displayed:

Application	Job Name	Job ID	#Images	Elapsed Time	Start	End	First I/A	Last I/A	Operator	Machine ID
A1	a1	3	21	00:00:27	11/11/2000	11/11/2000	FF:001.000.000	FF:005.001.003	1240579	dev-q29
A3	a3	2	120	00:00:48	11/11/2000	11/11/2000	FF:001.000.000	FF:017.001.001	1240579	dev-q29
B1	B11	2	36	00:00:19	11/5/2000	11/5/2000	FF:001	FF:003	1240579	dev-q29
	B11a	3	52	00:00:31	11/5/2000	11/5/2000	FF:001	FF:010	1240579	dev-q29
B14	b14	1	52	00:01:00	11/6/2000	11/6/2000	FF:001	FF:027	1240579	dev-q29
B2	b17	3	16	00:00:18	11/7/2000	11/7/2000	FF:001	FF:016	1240579	dev-q29
	B2	1	52	00:00:47	11/6/2000	11/6/2000	FF:001	FF:048	1240579	dev-q29
	b9				11/6/2000		FF:001		1240579	

NOTE: The format of the report cannot be changed.

Following are descriptions of the fields and buttons on the Reports Preview window:

Images — displays the number of images written to film.

Elapsed Time — the time it took to run the job.











Start/End — displays the dates that the job was started and completed.

First I/A and Last I/A — assigned to the images written to film.

Operator and Machine ID — who ran the job and the name of the Writer used to write images to film.

Date — displays the date that the report was printed/exported.

Buttons

	Goes to the first page.		Zoom/reduce the screen display (toggle)		
	Goes to the previous page.		Opens the Print dialog box for the default printer for the PC you are working on. NOTE: The printer cannot be changed.		
	Goes to the next page.		Opens the Export dialog box. Destination can be "Disk file" or "Mail via MAPI". Disk file is the default.		
	Goes to the last page.		Opens the Export dialog box. Destination can be "Disk file" or "Mail via MAPI". Mail via MAPI is the default.		
	Cancel	Cancels an action.		Close	Closes this window.

Help menu

The Help menu contains three options:

This window — opens the Help dialog box to display the on-line help page that applies to the currently active window.

Contents and Index — opens the Help dialog box to display the first page of the on-line help with Contents and Index tabs.

About — displays a window containing software copyright and version information.

4 AWIS Application

This chapter provides an overview of the windows you can access when using AWIS Application, as well as procedures for opening, verifying and running jobs.

See *Chapter 3, AWIS Administration* for an overview of the windows in AWIS Administration and procedures for setting up applications, film templates, defining a Writer, removing jobs from the system and printing a report.

- From the Start menu, select **Programs > AWIS** or click on the AWIS icon on the desktop.



The Archive Writer Interface Software window is displayed.

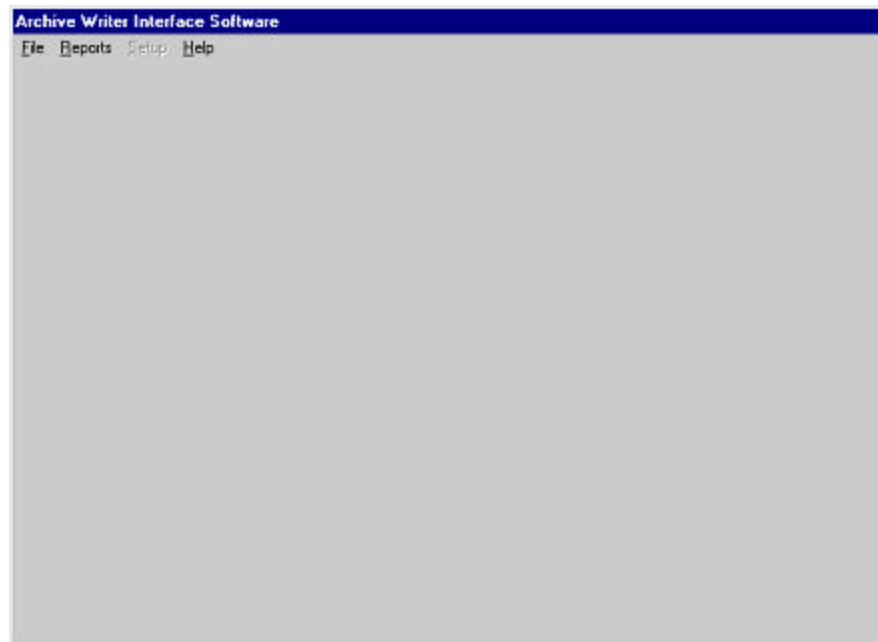

The menu bar provides the following options:

File — allows you to set up and run a new job, open an existing job that is not yet complete, verify a job that is complete and exit the AWIS application.

Reports — allows you to print a report of current AWIS jobs.

Setup — when setting up a new job, allows you to view the parameters associated with the selected Writer and application.

Help — provides access to AWIS help.

File Menu

The File menu contains the following options: New Job, Open Job, Verify Job and Exit.

File menu — New Job

When you select **New Job** from the File menu, the Archive Writer Interface Software window is populated with job setup fields, and the Setup menu option is enabled. The sections that follow provide field descriptions for each section of the Job Setup window. The sections are presented in the order in which is most efficient for setting up a job.

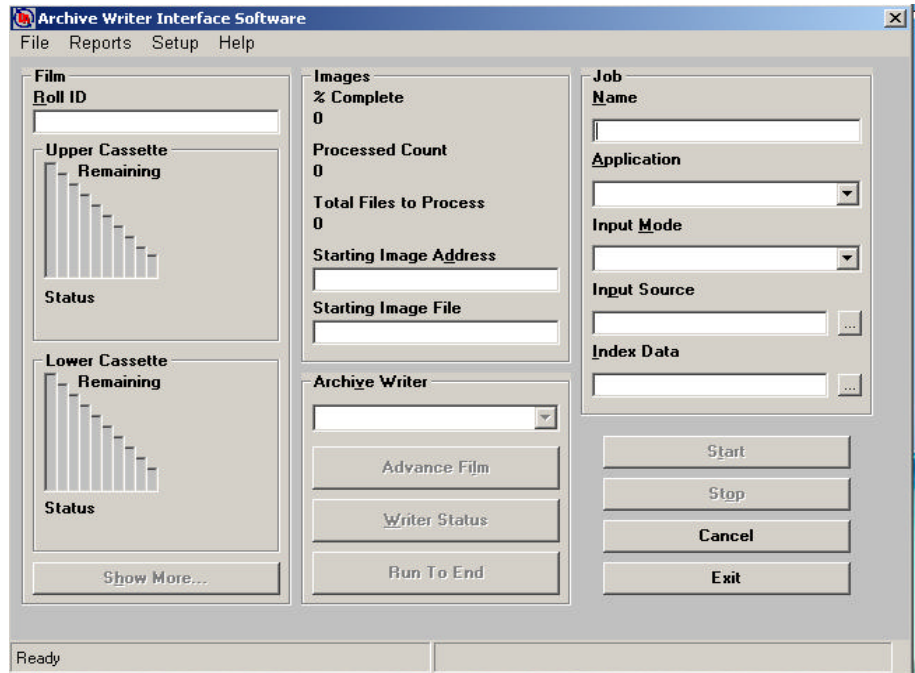

Job section

Following is a description of the fields in the Job section:

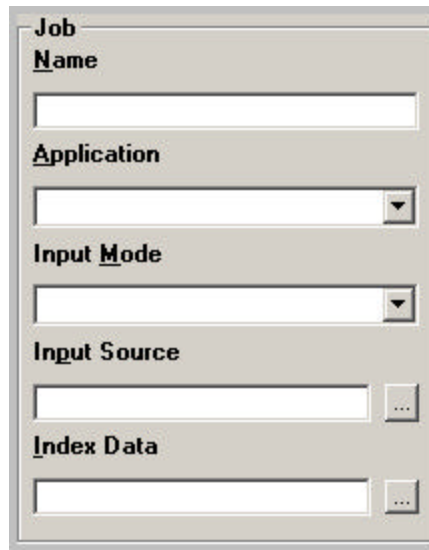
This is a close-up view of the 'Job' section from the software interface. It includes the following fields:

- Name**: A text input field.
- Application**: A dropdown menu.
- Input Mode**: A dropdown menu.
- Input Source**: A text input field with a browse button (three dots).
- Index Data**: A text input field with a browse button (three dots).

Name — enter the name of the job in this field (up to 25 characters including any keyboard character). You must make an entry in this field.

Application — select an application from the drop-down list. You must make an entry in this field. Once an application is selected, several fields are populated with values from the application template. All application and film template parameters can be viewed via the Setup menu option.

Input Mode — select an input mode: List file, Batch or Poll. This field is initially populated from the application template. If you change this value, the Input Source must also be changed.

- **List file:** an ASCII text file that contains the full pathnames to each image file that is to be written to film. The order in which the images are written is determined by the order in which the image file pathnames appear in the file.
- **Batch:** the image files within each directory are sorted according to the Windows file sorting algorithm and written to film in that order.
- **Poll:** poll files are sorted according to the Windows file sorting algorithm and are processed in that order. The directory is where the Poll files reside, not necessarily where the image files reside.

For more information, see Appendix A, *Input Modes*.

Input Source — enter a path to a valid List file, Batch or Poll directory (depending on the input mode you selected). You can use the ... (Browse) button to display the File Selection (for List files) or Directory Selection (for Batch or Poll modes) windows to assist you in location of the desired List file, Batch or Poll directory. The File Selection window and Directory Selection window are described on the next page. This field is initially populated from the application template.

Index Data — enabled only if the selected application specifies a custom Transfer file that uses an index data file.

This field is used to pass the name of the Index Data file to the user exit on a per-job-basis. For more information see the section entitled, “Application Setup - Transfer File tab” in Chapter 3. You can use the ... (Browse) button to display the File Selection window to assist you in locating the desired index data file. The File Selection window is described on the next page.

File Selection Window

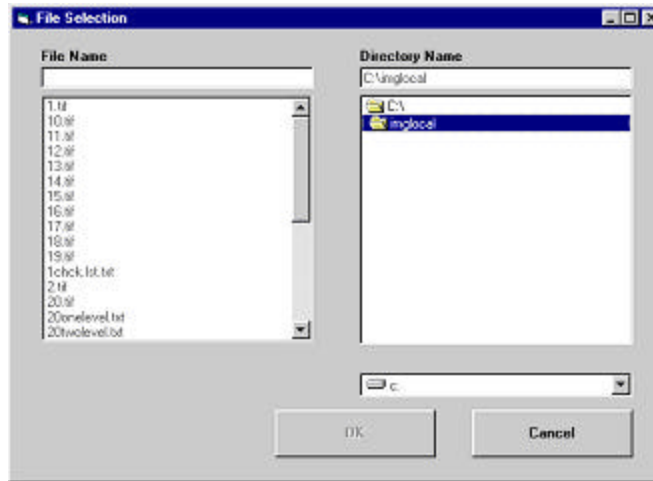

Drive — select the drive where the desired file is located.

Directory Name — select the directory in which to find the file name. Once selected, a list of files appears in the File Name list box.

File Name — select the file name from the list box. Once selected, the file name appears in the File Name text box.

OK — click to accept the List file and close the File Selection window.

Cancel — to ignore your selection and close the File Selection window.

To select a file:

1. Select the Drive.
2. Select the Directory Name.
3. Select the File name.
4. Click **OK**.

Directory Selection Window

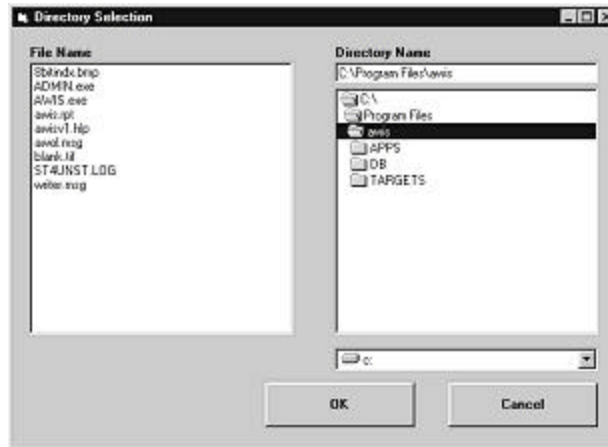

Drive — select the drive where the desired directory is located.

Directory Name — select the directory where the image or Poll file(s) reside. Once selected, any image or poll files within the directory are displayed in the File Name list box. If the input mode is batch, and the image files are in a subdirectory(ies), the File Name list box will remain empty.

OK — click to accept the Batch or Poll directory and close the Directory Selection window.

Cancel — to ignore your selection and close the Directory Selection window.

To select a directory:

1. Select the Drive.
2. Select the Directory Name.
3. Click **OK**.

Archive Writer section

When a Writer is selected, the system connects to the Writer. Once connected, the following options are enabled: Advance Film, Writer Status buttons; the Archive Writer Parameters selection under the Setup menu and the Show More button in the Film section.

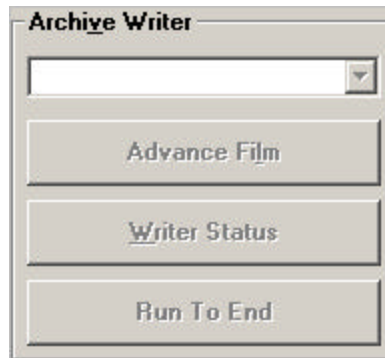

The Writer returns status information related to the film cassettes and this status is displayed in the Upper and Lower Cassette graphics in the Film section.

Archive Writer —select an available Writer from the drop-down list. You must make an entry in this field. Only Writers currently defined on the system are displayed. If a selected Writer is being used by another process, or is not powered up and

initialized, an informational message is displayed and you must select a different Writer.

Advance Film — opens the Advance Film dialog box, which is populated with the value specified via film template setup. This value can be changed if desired.

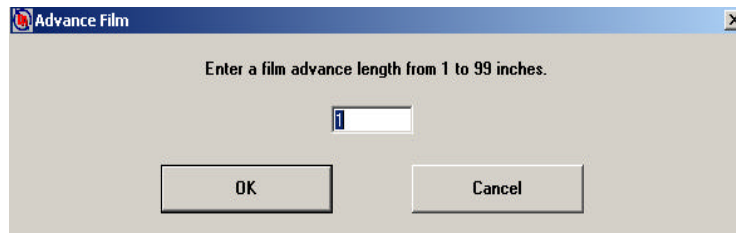

Writer Status — updates the information in the Film section graphics.

Run To End — enabled only after a job has been run. Displays the Run to End dialog box that provides the options to perform end-of-roll processing (writing of trailer page to film) and/or physically running the film completely on to the takeup spool. End-of-roll processing may not be enabled, depending on preceding actions.

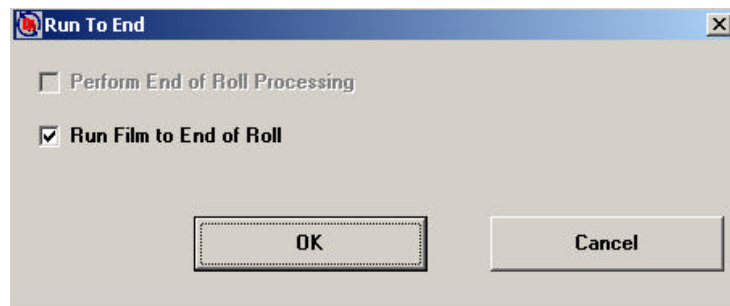

Film section

Following is a description of the fields in the Film section:

The screenshot shows a window titled "Film". It contains a "Roll ID" text box. Below it are two sections: "Upper Cassette Remaining" and "Lower Cassette Remaining". Each section features a bar chart with 10 bars of decreasing height from left to right, and a "Status" label below the chart. At the bottom of the window is a "Show More..." button.

Roll ID — this field is populated with a value after an application is selected in the Job section. The value is the next available number for that application based upon current records in the awis.mdb. This value can be changed if desired, using any number (up to 8 digits) that does not already exist in the awis.mdb for that application. This field must contain a value

Upper Cassette — displays the amount of film remaining in the upper cassette. This field is enabled upon successful connection to the selected Writer. This is informational only and cannot be changed.

Lower Cassette — displays the amount of film remaining in the lower cassette. This field is enabled upon successful connection to the selected Writer. This is informational only and cannot be changed.

Show More — when selected, the Additional Film Status window is displayed (shown next). This is informational only and cannot be changed.

Additional Film Status Window

The screenshot shows a window titled "Additional Film Status". It is divided into two columns: "UpperCassette" and "Lower Cassette". Each column has two text boxes: "Last Image Mark Written" and "Last Image Address Written". The values in the text boxes are: UpperCassette Last Image Mark Written: 1, UpperCassette Last Image Address Written: 00001.0000032, LowerCassette Last Image Mark Written: 0, LowerCassette Last Image Address Written: 0000.00.000.001. There is an "OK" button at the bottom right.

Last Image Mark Written (Upper and Lower Cassette) — displays the level of the last image mark written. If a cassette is not present in the Writer, the value will be 0.

Last Image Address Written (Upper and Lower Cassette) — displays the image address assigned to the last image that was written to the roll of film in that cassette. If a cassette is not present in the Writer, the value will be 0000.00.000.001.

Images section

The following fields are updated interactively as a job runs:

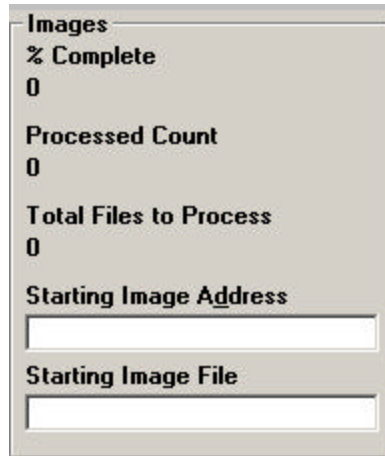

Images
% Complete
0
Processed Count
0
Total Files to Process
0
Starting Image Address

Starting Image File

% Complete — displays the percentage of the total for the images already processed.

Processed Count — displays the number of images already processed.

Total to Process — displays the number of images to process.

Starting Image Address — this field is populated with the value from the application template when an application is selected in the Job section. This value can be changed if desired, but the value must comply with the parameters specified in the

film template. For more information, see the section entitled, “Film Templates - Image Addressing tab” in Chapter 3. As a job runs, this field changes to show the “Last Image Address” that was assigned.

Starting Image File — this field is empty until a job is started. As a job runs, this field changes to show the “Last Image File” that was processed. Long file names will be truncated and cannot be viewed since the full pathname is displayed.

Buttons

Start — becomes enabled when a job name, application and Archive Writer have been specified. When you choose **Start**, processing takes place depending on the setting for Input mode.

- If Input mode is either batch or List file, processing of the image files begins.
- If Input mode is Poll, polling for Poll files begins.

Job progress is reported in the Images section.

Stop — becomes enabled when **Start** is selected. If you select **Stop** in the middle of processing, AWIS completes the processing of the current command transaction; the Images section will indicate where processing stopped.

In addition, if the Input mode is **Poll**, the following message is displayed:



- If you select **Stop Filming**, AWIS completes the processing of the current command transaction, then stops; the Images section will indicate where processing stopped.
- If you select **Stop Polling**, AWIS completes the job before stopping.

Cancel — cancels the New Job function and clears the Archive Writer Interface Software window.

Exit — exits the AWIS application.

Status bar

The bottom of the display is dedicated to the reporting of general status associated with the AWIS application. Typical items reported include, *Ready*, *Writing Images* and *Polling Input Directory*. In addition, at the end of a job, the total count of images written to film (actual pages) will be displayed.

Starting a new job

Before you begin make sure the film cassette(s) have been inserted correctly into the Writer. For more information about film cassettes, refer to the User's Guide for the *Kodak i9600 Series Writer*, A-61058.

1. Select the **AWIS** icon on the desktop or **Start>Programs>AWIS** to start the AWIS application function.
2. Select **File>New Job**. The Archive Writer Interface Software window is displayed.

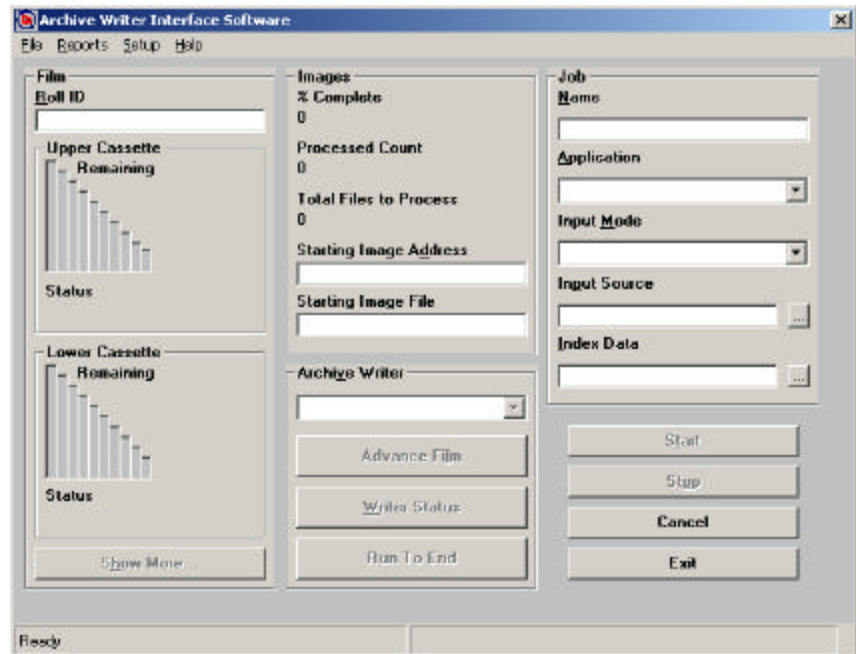

3. Enter the Job Name and Application. These fields must be completed.
4. Change the Input Mode and Input Source if desired. These fields must be completed. Enter the Index Data file full pathname if required for the application.

NOTE: The ... (Browse) buttons may be used to select the desired directory or file.

5. Select an Archive Writer. This is required.
6. Change the Roll ID if desired.
7. Change the Starting Image Address if desired. This field is required except when the application specifies "No indexing".

8. Click **Start**. The job will immediately start processing, unless the input mode is Poll mode, then AWIS will begin looking for Poll files. Upon completion of processing, the following message will be displayed:

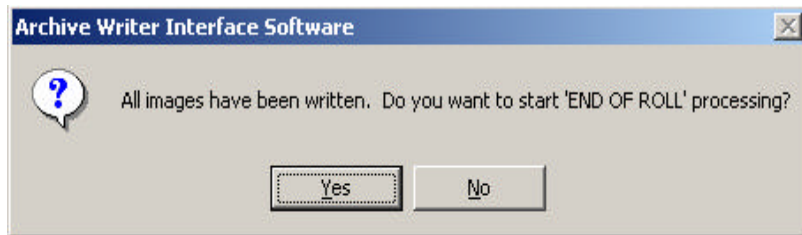

- If you select **No**, the New Job fields remain populated with current job information and the connection to the Writer is maintained. You can now specify a new input source and select **Start** to add more images to the same roll ID for that application, or **Cancel** or **Exit**.
- If you select **Yes**, a message will be displayed indicating that the roll is done, then the following will be displayed:

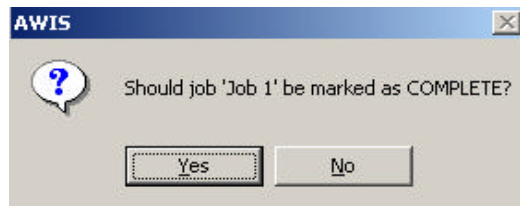

- If you select **Yes**, the job status is updated in the awis.mdb, the New Job function exits and the Archive Writer Interface Software window is cleared.
- If you select **No**, the Multi-Roll Processing dialog box is displayed. For more information see the next section entitled, "Multi-roll processing".

Multi-roll processing

When a single job contains more images than will fit on one roll of film, multi-roll processing should be used. This allows continuation of processing without having to setup and start another new job, and makes it unnecessary to batch images according to the capacity of a single roll.

Multi-roll processing may be initiated manually or automatically.

Manually — when a job is finished processing, if you perform end-of-roll processing but do not mark the job as complete, the Multi-Roll Processing dialog box will be displayed.

Automatically — when a job is processing and the film gets down to only 10 feet remaining, or the next document to be processed will not fit on the amount of film remaining, the Multi-Roll Processing dialog box will be displayed. (A 10-foot trailer is required at the end of a roll to facilitate successful retrievals, and the system does not allow splitting of multi-page documents across multiple rolls of film.)

Multi-Roll Processing

Roll ID for next roll

Current Roll ID
22

Next Roll ID
23

Starting I/A for next roll

Current Image Address
FF.005.001.003

Use next in sequence

Use Application default

Other

OK

Current Roll ID — is informational only and shows the roll ID for the roll that was just finished.

Next Roll ID — can be changed if desired, but cannot be the same as any existing Roll ID already associated with the current application in the awis.mdb.

Current Image Address — is informational only and shows the image address assigned to the last image on the roll that was just finished.

Starting IA for the next roll — can be one of the following:

- **Use next in sequence:** the IA assignment will continue from the previous roll, based upon the film mode and image addressing parameters in the film template, and the level of the first image. In the previous example, the starting IA could be FF.006.000.000 or FF.005.002.000, depending on the image level.
- **Use Application default:** the IA assignment will start with the value specified in application setup, e.g., FF.001.000.000.
- **Other:** the IA assignment will start with the value specified in this field. The value must comply with the parameters specified in the film template. For more information, see the section entitled, “Film Templates - Image Addressing tab” in Chapter 3.

NOTE: The Transfer file for each subsequent roll will be created in the same directory as the Transfer file for the first roll.

File menu — Open Job

When you select Open Job from the File menu, the Open Job window is displayed with information about the currently defined jobs that are not complete. Use this window to perform additional actions on these pending jobs.

NOTE: The columns and rows on the Open Job window can be resized by positioning the mouse on the column or row lines in the headings and moving the mouse, while holding down the left mouse button, to the desired position.

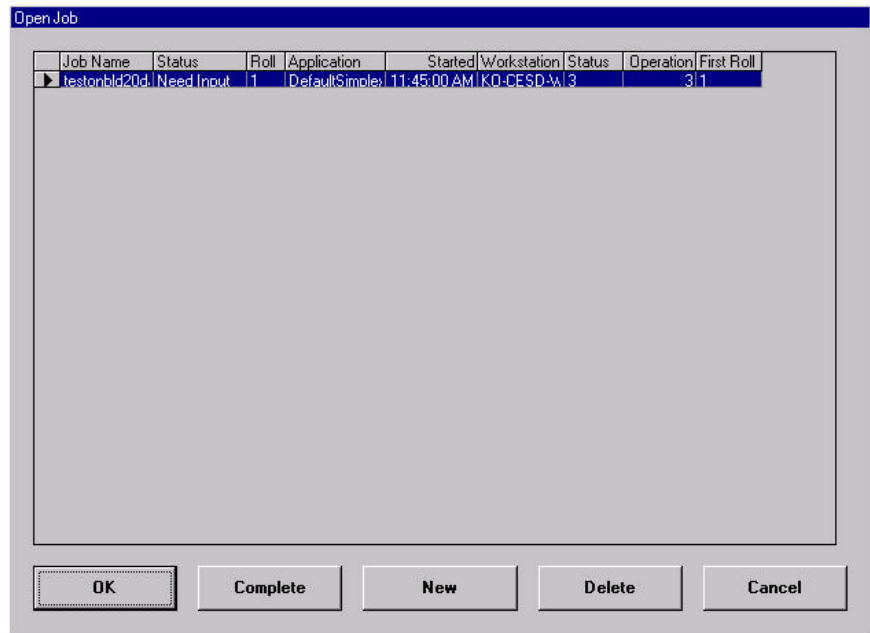

The window displays the following fields for each job:

Job Name: the name as entered by the operator when the job was created.

Status: status of that job. The following status can be displayed:

- **Need Input** — indicates that all images for the job were written to film but the job has not been marked as complete. Additional images can be added to the roll if desired.
- **Write Images** — indicates that all images for the job were not written to film due to some interruption of processing. The job can be restarted and resumed where it was interrupted. A job is not available to be marked as complete until all images are written.

Roll ID — the Roll ID assigned to the film when the job was run.

Application — the application used to run the job.

Started — date and time when this job was first started.

Workstation ID — name of the host PC from which the job was run.

Status Code and Operation Code — used internally by the system.

First Roll — used internally by the system.

Buttons

OK — opens a selected job. If any information needed to open the job is not available (e.g., the application template was deleted), an appropriate error message will be displayed.

Complete — updates the job status to complete and removes the job from the Open Job table. This is only enabled for those jobs whose status is “Need Input”.

New — displays the Archive Writer Interface Software window populated with empty New Job fields. For more information see the section entitled, “File Menu - New Job” in this chapter.

Delete — deletes a selected job from the Open Job table but unlike Purge in AWIS Administration, does not remove all job history from the database; transaction information is retained.

Cancel — closes the Open Job window and returns to the main AWIS window.

Opening a job

You can open a job in one of the following ways:

- Position the arrow on the line of the desired job name and click **OK**.
- Single-click on any line and click **OK**.
- Double-click on any line.

The Archive Writer Interface Software window is displayed, populated with the same fields used when starting a new job. The fields contain the values used when the job was run previously. The job status determines which fields contain values. For more information about using these fields see the section entitled, “File menu - New Job” in this chapter.

NOTE: You can only work with one job at a time, even though you can select more than one job.

File menu — Verify job

When you select **Verify Job** from the File menu, the Verify Job window is displayed. You can only verify one job at a time. This feature can be used to facilitate job and roll tracking for quality control and audit purposes. Once a roll is successfully verified for image quality, etc., the job status can be changed to indicate that, and the job information can be purged from the system, if desired, using AWIS Administration.

The screenshot shows the 'Verify Job' window with two tables and four buttons. The 'Jobs' table lists two jobs, and the 'Rolls' table lists one roll. The buttons are 'Resubmit', 'Complete', 'Verify', and 'OK'.

Job Name	Application	Started	Status	Operator	Workst
checks	Default	6/26/97 6:12:36 AM	Complete	farren	FARRE
Letters	DneLevelSimplex	6/26/97 10:49:26 AM	Complete	farren	FARRE

Roll ID	Total Images	First I/A	Last I/A	Completed
611	3		1	6/26/97 6:12:57 AM

Buttons: Resubmit, Complete, Verify, OK

Jobs — displays information about the jobs that have been completed, including the job name, the application used to run the job, the date and time that the job was started, the fact that the job was completed, the Login ID of the operator who completed the job, the workstation ID of the host PC from which the job was run, the Roll ID assigned to the film when the job was run, and a status code of 2 (the code for *Complete*).

Rolls — displays information for the roll of film associated with the selected job, including the Roll ID assigned to the film when the job was run, the total number of images written to film using that job, the first and last image addresses assigned using that job, the date and time that the job was completed, and the roll number indicating whether the job required more than one roll of film.

Buttons

Resubmit — job status is changed to *Write Images* and the job is removed from the Jobs table here. The job can be accessed via **File>Open** and the images can be written to film again using the original job setup. This is useful when the finished film does not meet quality control requirements.

Complete — if a job in the table has been changed to *Verified*, it can be reset to *Complete* using this button.

Verify — job status is changed to *Verified* in this table.

OK — saves status changes made to any jobs via Complete and Verify and closes the Verify Job window.

File — Exit

Select **File>Exit** to close the AWIS Application.

Reports menu

The Reports menu allows you to print and/or export a report. See Chapter 3, AWIS Administration for information on printing and/or exporting reports.

Setup menu

Enabled only when setting up and running jobs, after a Writer or application has been selected. From this menu you can view the parameters associated with the Writer and the application setup.

5 Troubleshooting

When checking AWIS.LOG for errors, scroll to the first error with the same time stamp as the last error. This begins the error and reporting sequence for the current error.

NOTE: We do not recommend using the diagnostic error logging level; this is intended for use by Kodak Service.

Errors numbered 1000 through 9999 in AWIS.LOG are AWIS errors. If the error was caused by an error on the Writer itself, an error numbered 100 through 999 may follow the AWIS error(s) in the log.

Writer errors 103 through 229 are recoverable by rebooting the Writer. If any of the other Writer errors are not recoverable by rebooting the Writer, call the Kodak Customer Response Center or your integrator.

Generally, 100-series errors are warnings/informational messages, 200-series errors are warnings/correctable situations, 300-series errors are development debug tools (should not show up in the field), 700-series are critical imaging chain errors, 900-series are other critical system errors.

Setup problems

If you are having problems with the Writer, follow the instructions for the applicable category below.

Cannot connect to the Writer

1. Boot the Writer.
2. If you cannot connect to the Writer from AWIS, reboot the Writer and then reboot the workstation that AWIS is running on.
3. If you still cannot connect to the Writer, contact the System Administrator.

Bad Image

If a bad image is detected during writing of images to film, a dialog box provides the name of the bad file. It is up to the user to replace this file with any good TIFF file (you may use a blank TIFF). The bad file must be replaced, it CANNOT be deleted.

NOTE: Running the input files through the TIFFCHKR application first will help to identify non-compliant files prior to processing. For more information see Appendix B.

Check Image Address

If the operator receives IA format errors, the starting image address for all jobs needs to be verified before the job is started.

AWIS error log

The chart below defines AWIS error numbers, the corresponding messages, and an explanation of what each error signifies. In certain cases, corrective actions are provided.

Key: %s Actual message contains character designator or file name(s).
 %d Actual message contains numeric value.

Code	Message	Description
0	Success	This is the normal return status for all operations. The error log will not usually contain any of these messages.
1000	Error opening file:%s.	The specified file cannot be opened. This usually happens when the file does exist, and may be caused by abnormal operation of the Writer (such as powering the Writer down or setting it to offline while image writing is in process). This may also be caused by manually deleting files AWIS expects to find, such as the index data file and template files.
1002	Error reading file:%s.	The specified file cannot be read. This can be caused by the file not existing, by other programs having the file locked, or by a corrupted file. This can also be caused by low memory conditions, where there is not enough memory to allocate a buffer for reading the file contents.
1004	No index data file specified	The application did not provide the name of an index data file. This is an informational message only.
1007	Failed to write to file%s.	The file was successfully created, but a failure occurred in writing to the file. This may be caused by disk failures or running out of disk space. If the file is being written to the Writer drive, this error may be caused by the Writer being shut down or by an error occurring in the Writer that removes or corrupts the remote drive connected to the Writer.
1008	Failed to rename file%s to%s.	An attempt to rename a file has failed. This may be caused by the destination file already existing, or by a failure of the disk the file resides on.
1009	Cannot write file%s: no data to write to it...	An internal program error has caused an attempt to write a zero-length data buffer to the file. This error should never occur.
1010	Error creating file%s.	Failed to create the specified file. This may occur if the disk the file is to be created on is corrupted, missing, or out of space.
1011	Error closing file%s.	Failed to close the specified file. This may occur if the disk is corrupted.
1012	Error code%d returned during attempt to create file%s.	Failed to create the specified file. This may occur if the disk the file is to be created on is corrupted, missing, or out of space. The error code is documented in the Microsoft Visual C++ documentation. Refer to the section on error codes returned from the file IO functions.

Code	Message	Description
1013	Error code%d returned during attempt to read file%s.	Failed to read the specified file. This may occur if the disk the file is on is corrupted or missing. The error code is documented in the Microsoft Visual C++ documentation. Refer to the section on error codes returned from the file IO functions.
1014	Error code%d returned during attempt to write to file%s.	Failed to write to the specified file. This may occur if the disk the file is on is corrupted or missing. The error code is documented in the Microsoft Visual C++ documentation. Refer to the section on error codes returned from the file IO functions.
1016	Error during attempt to create directory%s.	Failed to create temporary directory to place single-page TIFF files from multi-page TIFF files.
1017	Couldn't send an input file specification to the Writer for file%s.	Socket error.
1018	Couldn't send an output file specification to the Writer for file%s.	Socket error.
1019	Couldn't get an input file specification acknowledgment from the Writer for file%s.	Socket error.
1020	An input file specification contained an invalid filename:%s.	Socket error.
1021	An input file specification acknowledgment contained an invalid value:%c.	Socket error.
1022	And input file specification acknowledgment contained an invalid value:%c.	Socket error.
1023	Couldn't get a file content acknowledge from the Writer for file%s.	Socket error.
1024	Failure writing contents of%s to Writer.	Socket error.
1025	Couldn't send the file content acknowledgment to the Writer for file%s.	Socket error.
1026	Couldn't write file%s to the Writer.	Socket error.
1027	Couldn't read file%s from the Writer.	Socket error.
1028	Couldn't get an output file specification acknowledgment from the Writer for file%s.	Socket error.
2000	File open error	Could not open file.
2010	Socket Error%d	
2012	Socket Error%d. Host sockets have been reset.	The Writer has reset the socket connection.
2013	Socket Error%d. No socket data found. Check Services file.	Port and protocol information could not be found. The Services file may not have entries for the socket connections.
2014	Socket Error%d. Host not found. Check Writer name.	The Writer name could not be found either in the host file or on the network.
2016	Can't find winsock.dll.	The winsock.dll is not on the system.

Code	Message	Description
3000	Error writing command%s.	Failed to create a command file containing the specified command. This may be caused by the Writer being offline or inoperable. This problem can be corrected by making sure the Writer is online and the Writer disk is available. It may be necessary to reboot the Writer and to make sure the NFS connection to the Writer is working properly.
3001	Error sending command.	Failed to create a command file containing the specified command. This may be caused by the Writer being offline or inoperable. This problem can be corrected by making sure the Writer is online and the Writer disk is available. It may be necessary to reboot the Writer and to make sure the NFS connection to the Writer is working properly.
3002	Error creating semaphore.	Failed to create a semaphore file. This may be caused by the Writer being offline or inoperable. This problem can be corrected by making sure the Writer is online and the Writer disk is available. It may be necessary to reboot the Writer and to make sure the NFS connection to the Writer is working properly.
3004	Error in Astring parse.	An internal programming error has occurred in the AWOL parsing routine. This error should never occur.
3005	Response file for command %d, no response value in file.	An empty Response file has been created by the Writer. This may be due to an internal fault in the Writer. This problem may be corrected by closing the application and restarting the Writer.
3009	Error parsing response parameter number.	An internal programming error has occurred in the AWOL parsing routine in attempting to parse the response parameter number from the string. This error should never occur.
3010	Error parsing Archive Writer error number.	An internal programming error has occurred in the AWOL parsing routine in attempting to parse the error number from the response file. This error should never occur.
3012	Parameter number out of range.	The parameter number contained in the response file is not valid. This error should never occur.
3013	Image buffer full.	The internal image buffer is full. This is normal operation. This error should never appear in the error log file.
3014	Invalid Writer drive.	The application has supplied a drive letter that is invalid. Make sure the specified drive letter is correct.
3016	Command timed out. Command: %s.	The Writer has not responded to the command within the allowed period of time (usually 90 seconds). Check that the Writer is online and that the drive assigned to the Writer is available. It may be necessary to restart the Writer.
3018	No more files.	This is a normal internal status indicating that no more files are available for processing.
3021	File mismatch. Expected: %s, got: %s, original file: %s.	The response file returned by the Writer contains the wrong file specification. This error indicates a communication or other internal failure in the Writer and may be corrected by closing the application and restarting the Writer.
3022	No image address in %s (Image log file).	The image log file returned by the Writer does not contain a valid image address where one was expected in the file. This error indicates a communication or operational failure in the Writer and may be corrected by closing the application and restarting the Writer.

Code	Message	Description
3023	Can't open transfer file.	The transfer file cannot be opened. This may be caused by a corrupted hard disk or by an invalid path specified for the location of the transfer files.
3027	Rollname too long.	More than 8 characters have been specified for the roll name.
3031	Command buffer empty.	An internal programming error in the AWOL DLL has occurred.
3032	No more disk space.	There is not enough disk space on the Writer drive to create a file. This error should never appear in the error log.
3033	Can't overwrite command.	This is an internal program status and will never appear in the error log file.
3034	Failed to copy file to Writer.	A file cannot be copied to the Writer. This is caused by a failure of the communication link with the Writer or by an internal failure in the Writer. Correct this by closing the application and restarting the Writer.
3036	Could not find response file, %s.	A request has been made for information from the Writer, the Writer has executed the command, but no response file was returned. This is caused by a failure of the communication link with the Writer or by an internal failure in the Writer. Correct this by closing the application and restarting the Writer.
3037	Error creating the film leader.	An error was returned from the Writer in attempting to create a film leader. This may be caused by a failure of the film cassette, by not having enough film in the cassette, or by an internal error in the Writer. Correct this problem by making sure the film cassette contains enough film and that the Writer communication link is working properly.
3038	Error in image address on cassette.	The film cassette contains an invalid image address.
3040	Error sending IMC command.	The IMC command could not be successfully sent to the Writer. This is caused by a failure of the communication link with the Writer or by an internal failure in the Writer. Correct this by closing the application and restarting the Writer.
3041	Error sending Image Frame command.	The command to set the next image frame could not be successfully sent to the Writer. This can be caused by a failure of the communication link with the Writer or by an internal failure in the Writer. Correct this by closing the application and restarting the Writer.
3043	Error sending System command to Writer.	The System command could not be successfully sent to the Writer. This is caused by a failure of the communication link with the Writer or by an internal failure in the Writer. Correct this by closing the application and restarting the Writer.
3044	Error sending command to get remaining film.	The command to get the remaining film could not be successfully sent to the Writer. This is caused by a failure of the communication link with the Writer or by an internal failure in the Writer. Correct this by closing the application and restarting the Writer.

Code	Message	Description
3045	Error sending command to get the film status.	The command to get the film status could not be successfully sent to the Writer. This is caused by a failure of the communication link with the Writer or by an internal failure in the Writer. Correct this by closing the application and restarting the Writer.
3046	Error sending command to get the film cassette data.	The command to get the cassette data could not be successfully sent to the Writer. This is caused by a failure of the communication link with the Writer or by an internal failure in the Writer. Correct this by closing the application and restarting the Writer.
3047	Error sending command to set the diagnostic port.	The command to set the diagnostic port could not be successfully sent to the Writer. This is caused by a failure of the communication link with the Writer or by an internal failure in the Writer. Correct this by closing the application and restarting the Writer.
3048	Error sending command to set the status monitor port.	The command to set the status monitor port could not be successfully sent to the Writer. This is caused by a failure of the communication link with the Writer or by an internal failure in the Writer. Correct this by closing the application and restarting the Writer.
3049	Error sending command to set the image writing parameters.	The command to set the image writing parameters could not be successfully sent to the Writer. This is caused by a failure of the communication link with the Writer or by an internal failure in the Writer. Correct this by closing the application and restarting the Writer.
3051	Error sending command to set the date and time in the Writer.	The command to set the internal date and time could not be successfully sent to the Writer. This is caused by a failure of the communication link with the Writer or by an internal failure in the Writer. Correct this by closing the application and restarting the Writer.
3052	Error sending command to set the frame annotation.	The command to set the frame annotation could not be successfully sent to the Writer. This is caused by a failure of the communication link with the Writer or by an internal failure in the Writer. Correct this by closing the application and restarting the Writer.
3053	Error getting command 42, get frame annotation.	The response file for the command to get the frame annotation does not contain a valid response. This is caused by a failure of the communication link with the Writer or by an internal failure in the Writer. Correct this by closing the application and restarting the Writer.
3054	Error getting command 19, get system command.	The response file for the command to get the Writer system parameters does not contain a valid response. This is caused by a failure of the communication link with the Writer or by an internal failure in the Writer. Correct this by closing the application and restarting the Writer.

Code	Message	Description
3055	Error getting command 4, get leader length.	The response file for the command to get the leader length does not contain a valid response. This is caused by a failure of the communication link with the Writer or by an internal failure in the Writer. Correct this by closing the application and restarting the Writer.
3056	Error getting command 11, get image frame.	The response file for the command to get the next image frame does not contain a valid response. This is caused by a failure of the communication link with the Writer or by an internal failure in the Writer. Correct this by closing the application and restarting the Writer.
3057	Error getting command 38, get IMC.	The response file for the command to get the IMC settings does not contain a valid response. This is caused by a failure of the communication link with the Writer or by an internal failure in the Writer. Correct this by closing the application and restarting the Writer.
3064	Expected to get response for page %d of file %s; instead got page %d.	This is an internal diagnostic message.
3068	Error getting command 57, get power down interval.	Error using command 57, get power down interval. Reboot Writer.
3069	Error getting command 58, set power down interval.	Error using command 58, set power down interval. Reboot Writer.
3070	Error getting command 60, get interdocument gap.	Error using command 60, get interdocument gap.
3071	Error getting command 59, set interdocument gap.	Error using command 59, set interdocument gap.
3072	Error getting command 20, get version numbers.	Error using command 20, get version number.
3073	Error sending command 40, get online status.	Error using command 40, get online status.
3074	Error sending command 1, advance film.	Error sending command 1, advance film.
3075	Could not successfully read status file, %s.	Failed reading status file. Reboot Writer.
3078	Could not convert text file %s to a TIFF file.	Problem converting text file to TIFF.
3079	Using the 'NumCommands' value of %d found in registry for total # of simultaneous AWIS print commands.	Informational message. AWIS is using a value in the system registry that has been entered by a System Administrator or Kodak representative for purposes of performance enhancement. This value sets the number of simultaneous print commands that can be active.
3080	The 'NumCommands' value found in registry (%d) is either zero or exceeds system maximum of %d. Setting to system default of %d.	Warning message to indicate to System Administrator or Kodak representative that an invalid value has been entered into the system registry. This value is intended to enhance performance, but will not be used because it is outside of the allowable limits. System will use a default value instead of the illegal value found in the registry.

Code	Message	Description
3081	Using the 'NumFiles' value of %d found in registry for max number of image files per AWIS print command.	Informational message. AWIS is using a value in the system registry that has been entered by a System Administrator or Kodak representative for purposes of performance enhancement. This value sets the maximum number of image files that can be sent in a single print command.
3083	The 'NumCommands' value (%d) multiplied by the 'NumFiles' value (%d) exceeds the system limit of %d. Using default values of %d and %d.	Warning message to indicate to System Administrator or Kodak representative that although valid NumCommands and/or NumFiles value(s) have been entered into the system registry, the two values together produce an invalid result. These values are intended to enhance performance, but will not be used because their product is outside of the allowable system limit. System will use default values for both fields.
3084	Setting number of simultaneous print commands to %d; max number of image files per command to %d.	Informational message indicating what 'total print commands' and 'max image files per command' values AWIS will use.
3085	Unable to retrieve AWIS installation directory from registry.	AWIS installation directory is not in the registry.
3087	While forming a command, had to insert a print remaining command after file %s.	Moved Writer back to A channel when uneven amount of images is present for duplex film.
3090	The 'FileWaitTime' value found in registry (%ul) is invalid. Setting to system default of %ul.	FileWaitTime in registry is invalid. Using the default values.
3091	Using the 'FileWaitTime' value of %ul found in the registry.	Using FileWaitTime registry value.
4001	Not enough film on roll.	There is not enough film on the roll to write the images. Correct this by increasing the amount of unexposed film in the cassette.
4008	Can't flush Writer.	See preceding error messages for root cause of problem. A communication failure has occurred which prevents Command 58 from deleting files from the Writer directories. Possible actions: <ul style="list-style-type: none">• Replace the battery in the film cassette.• Adjust communication control values on the Advanced tab. Launch AWIS Administration and select from the menu bar: File>Options>Advanced. Enter these values on the Advanced tab: Number of Commands: 4; Number of Files: 4; File Retry Count: 40; Retry Delay: 2000; Transaction Timeout: 300.• Close the application and restart the Writer.
5000	End of Image Writing. All images supplied by the application have been written.	This is a normal, successful condition.
5001	List file not found: %s.	The List file supplied by the application cannot be found. Correct this problem by specifying a valid List file.
5006	No images found in image list or image directory.	The application has specified a directory (in Batch mode) or a List file (in List mode) that contains no images to be written.
5007	No images found in Cover Page directory.	The application has specified a directory for cover (header) pages to be written which contains no images.

Code	Message	Description
5008	No images found in Trailer Page directory.	The application has specified a directory for trailer pages to be written which contains no images.
5009	No images found in Image List File or in Image Directory.	The application has specified a directory (in Batch mode) or a List file (in List mode) that contains no images to be written.
5012	Inconsistency between Image Address Field Widths and/or Offset Addressing and/or selected filming Level.	
5013	%s %s	No images in specified cover directory or specified trailer directory.
5014	%s %s	No images in specified cover or specified image directory.
5015	%s %s	No images in specified image or specified trailer directory.
5016	%s %s %s	No images in specified cover or specified trailer or specified image directory.
5018	SetCurrentFile, file at %d position in file list is %s; file expected at this position was %s.	This is an internal informational message.
5019	File %s exceeds max file size for archive Writer in simplex mode of %d bytes; its size is %d bytes.	File too large for Writer in simplex mode. Possible causes: <ul style="list-style-type: none"> • Grayscale images may be present in Begin Roll processing directory. • Application defined as single-page given multi-page input.
5020	File %s exceeds max file size for archive Writer in duplex mode of %d bytes; its size is %d bytes.	File too large for Writer in duplex mode.
5021	Memory reallocation error.	There is not enough memory to perform the current operation. This can be corrected by adding more memory to the computer, by specifying a larger page file size in Windows setup, by reducing the size of the image List file or by reducing the number of images in the batch directories.
5023	Error resetting file list.	The file specified by the application cannot be found in the List file (in List mode) or in the image directory (in Batch mode). This problem is corrected by verifying the List file or batch input directories contain the file specified by the application.
5027	No index page directory specified.	The application did not supply a path in the JobPath parameter for creating index pages. This is an internal programming error.
5028	No Writer path specified.	The application did not supply a valid Writer path. This is an internal programming error.
5029	Cannot open image log file: %s.	The image log file cannot be opened. This may be caused by insufficient hard disk space.
5030	Cannot write to image log file: %s.	The image log file cannot be written to. This may be caused by insufficient hard disk space.
5031	Cannot write to transfer file:%s.	The transfer file cannot be written to. This may be caused by insufficient hard disk space.

Code	Message	Description
5032	Cannot allocate memory.	There is not enough memory to perform the current operation. This can be corrected by adding more memory to the computer, by specifying a larger page file size in Windows setup, by reducing the size of the image List file or by reducing the number of images in the batch directories.
5034	Error found in response file for file %s (page %d). Got Writer Error number %d.	An error has been detected in the response file for the filename specified. This may be caused by an internal error in the Writer. The interpretation of the error code should appear in the error log following this error.
5035	%s is not a valid Digital Archive Writer path - the %s directory is missing.	The specified Writer path does not appear to be valid because the specified directory is missing. Correct this by closing the application and restarting the Writer.
5036	Cannot communicate with Writer (failed to set next transaction number).	Correct this by closing the application and restarting the Writer.
5038	Not enough space on your hard disk.	You need at least 1MB of free space. Your hard disk does not have enough space for AWIS to perform its normal operations. Correct this problem by increasing your free disk space.
5039	Archive Writer cannot be reset to continue processing.	The command to reset the Writer has failed. Close the application and restart the Writer.
5041	A cassette needs to be loaded into the Archive Writer.	There are no cassettes in the Writer. If you do have a cassette in the Writer, some kind of mechanical or electrical problem in the Writer has failed to detect the presence of the cassette.
5042	Cannot proceed until the Archive Writer is put in Online mode.	The Writer is currently set to Offline. Correct this by using the front panel buttons on the Writer to set the mode to Online.
5043	Writer in recoverable error state. Fix error above and restart.	This is an informational message indicating that the Writer may be restarted from the current error condition.
5045	Writer error has occurred.	Check previous error messages in error log file.
5046	The image address provided must have a "0" value for the Level 1 part of the image address.	Check addressing setup in the film template.
5048	Line %d of List file %s contains %d dashes preceding the filename; maximum number of dashes allowed is %d.	AWIS encountered a line in the List file where there was more than the allowed number of dash characters preceding the file name. Each dash on a line indicates the file is to be indexed one level lower than the index level specified for the job. For a 2-level job, the maximum number of dashes on a line is two; for a 1-level job, it is one. For example, in a 2-level job, two dashes in a List file line entry would cause the file to be indexed at level zero (two level minus two dashes equals zero). Note that only the first line on which the violation was found is flagged here; the user should check the entire List file to ensure that all lines are correct. Change the List file to meet the file specification requirements.
5049	Film template requires the upper cassette to be loaded into the archive Writer.	Put upper cassette in the Writer.
5050	Film template requires the lower cassette to be loaded into the archive Writer.	Put lower cassette in the Writer.

Code	Message	Description
5051	Upper cassette battery needs to be replaced.	Replace upper cassette battery.
5052	Lower cassette battery needs to be replaced.	Replace lower cassette battery.
5053	Upper cassette improperly inserted.	The upper cassette is installed incorrectly. Remove the cassette and install it properly.
5054	Lower cassette improperly inserted.	The lower cassette is installed incorrectly. Remove the cassette and install it properly.
5055	Cassette access door is open.	Cassette access door is open.
5057	Unable to load language files on Writer.	Failed to load language files on the Writer. Reboot Writer.
5058	Unable to access registry.	Failed to access registry. Check registry entry.
5059	The controller version number on the archive Writer is %s. A version of %s or greater is needed to run with the AWIS application software.	Check the version numbers for AWIS and the Writer and report the differences to Service.
5060	Bad ASCII character in text file %s.	Check ASCII file. Character not in character set 0-255.
5061	Line too long in text file %s.	Check ASCII file. The line is greater than 80 characters.
5062	Too many lines in text file %s.	Check ASCII file. There are more than 66 lines.
5065	The first line in List file %s must be specified to be indexed either at level %d or at level zero.	The first file specified in a List file must be indexed either at the job level or as a level zero image. In the List file specified in the error message, the first line contained a single dash, indicating the first file in a two-level job was to be indexed at level 1. This is not legal. If the List file is really a continuation of a previous job, the List file must be broken apart on document boundaries. Fix the List file such that the first line in it has no dashes.
5066	Unable to open or read file %s to interrogate TIFF tags.	Check that file is present and is a valid TIFF file.
5067	An archive Writer is not mapped to drive %s.	Returned from Initialize if FindFirstFile call returns nonexistent path for the ArchiveWriterPath provided. This differentiates from 5035 where the drive provided is not an Writer, but it exists.
5068	Standalone AWOLArchiveWriter class method called with bad listtype value: %d.	
6000	Sending command to get remaining film.	This is an internal diagnostic message.
6001	Application told us to terminate.	This is an internal diagnostic message.
6004	Opening transfer file and image data file.	This is an internal diagnostic message.
6005	Sending a group of images.	This is an internal diagnostic message.
6008	Write Images Method: %s.	This is an internal diagnostic message.
6009	Exiting WriteImages with return code %d (%s).	This is an internal diagnostic message.

Code	Message	Description
6009	Exiting Writelimages with return code %d (%s).	This is an internal diagnostic message.
7010	Invalid restart mode.	Not a valid restart mode.
8000	No user exit DLL found "AWOLEXIT.DLL".	No user exit named AWOLEXIT.DLL found in the Window's system directory.
8001	User exit %s not found.	User exit name not found in AWOLEXIT.DLL.
8002	Error in user exit %s.	Error in user exit. Check text returned from user exit.

Writer errors

The chart below defines Writer error numbers, the corresponding error messages, and an explanation of what each error signifies.

Code	Message	Description
103	FD Cassette Access Door Closed	The cassette access door was closed.
100	FD End Of Roll Warning	The film remaining in the upper cassette is equal to or less than 3 feet.
201	FD Ten Foot Warning	The film remaining in the upper cassette is equal to or less than 10 feet.
202	FD Fifteen Foot Warning	The film remaining in the upper cassette is equal to or less than 15 feet.
203	FD Film Breakage Upper Cassette	The film drive servo reported a loss of motion on the upper cassette's film encoder. Either the cassette is out of film or it is a hardware error.
204	FD Film Breakage Lower Cassette	The film drive servo reported a loss of motion on the lower cassette's film encoder. Either the cassette is out of film or it is a hardware error.
205	FD Out Of Film Upper Cassette	The film remaining in the upper cassette is equal to or less than 5 feet.
206	FD Out Of Film Lower Cassette	The film remaining in the lower cassette is equal to or less than 5 feet.
207	FD Low Battery Upper Cassette	The battery in the upper cassette is low.
208	FD Low Battery Lower Cassette	The battery in the lower cassette is low.
209	FD Loss Of Comm Upper Cassette	The battery in the upper cassette is dead or there is a hardware problem.
210	FD Loss Of Comm Lower Cassette	The battery in the lower cassette is dead or there is a hardware problem.
211	FD Cassette Access Door Open	The cassette access door was opened.
212	FD Upper Cassette Inserted Improperly	The upper cassette was inserted improperly.
213	FD Lower Cassette Inserted Improperly	The lower cassette was inserted improperly.
214	FD Invalid Num Cassettes	Configuring the number of cassettes required with an invalid number.
215	FD CP Invalid Fixed Length	Configuring the fixed length advance with an invalid length.
216	CD CP Invalid Message Data	Command Processor: error in message data invalid data was passed with a command.
217	CD CP Unknown Request	Command Processor: invalid command received.
218	FD CP Proc Illegal FDS Cmd	Unknown film drive request.
219	FD CP Invalid Leader Length	Advancing film or setting the leader length with an invalid amount.
220	FD CP Invalid Tension Length	Setting the tension length with an invalid amount.
221	FD Cassette Filmlengths Differ	The film amounts between the upper and lower cassettes differ by more than 6 feet.
222	FD Cassette Image Address Differ	The image addresses in the upper and lower cassettes differ.

Code	Message	Description
223	FD Cassette Roll Numbers Differ	The roll numbers in the upper and lower cassettes differ.
224	FD Cassette Sides Differ U1 L2	The upper cassette is on Side 1 and lower cassette is on Side 2.
225	FD Cassette Sides Differ U2 L1	The upper cassette is on Side 2 and lower cassette is on Side 1.
226	FD End Of Roll Warning Duo Side A	The end of a roll for duo Side A has been reached.
227	FD End Of Roll Warning Duo Side B	The end of a roll for duo Side B has been reached.
228	FD Upper Cassette Not Present	The system is configured for two cassettes and the upper cassette is not present or the system is configured for one cassette and both cassettes are not present.
229	FD Lower Cassette Not Present	The system is configured for two cassettes and the lower cassette is not present or the system is configured for one cassette and both cassettes are not present.
230	EH WRIB Kvalue Too Big	WRIB error: PM2 K value too big.
231	EH WRIB Cannot Process Tiled Image	WRIB error: Cannot process tiled images.
232	EH WRIB Cannot Process G4 Multistrip Image	WRIB error: Cannot process Group 4 multi-strip images.
233	FD Invalid Roll Number	An invalid roll number was entered. Either it was non-numeric or it was too long.
234	FD Invalid Job Number	An invalid job number was entered. Either it was non-numeric or it was too long.
236	CC II File Opening Error	
#	Message	Explanation
237	CC II File Read Error	
238	EH IC Invalid Image Origin	Image Composition invalid image X, Y origin.
239	EH IC Invalid Image Scaling	Image Composition invalid image scaling.
240	EH IC Image Too Long	Image Composition scaled image too long.
241	EH IC Image Too Wide	Image Composition scaled image is too wide for frame.
242	EH IC Invalid Image Limits	Image Composition invalid image frame limits.
243	EH IC Invalid Image Orientation	Image Composition invalid image orientation.
244	EH IC Invalid Image Polarity	Image Composition invalid image polarity.
245	EH IC Invalid Image Resolution	Image Composition invalid image resolution.
246	EH IC Invalid Scaling Factor	Image Composition invalid image scaling factor.
248	EH DOS Disk Init Transaction Failed	Could not instantiate a command given a semaphore file's contents.
250	EH DOS Disk Command File Open Failed	Cannot open the host application interface manager's command file that was written.
251	EH DOS Disk Invalid Command Id	Command ID for a command is not one of the supported command IDs.
252	EH DOS Disk Command Parameters Invalid	Parameters not valid for a command (e.g. wrong parameter IDs).
253	EH DOS Disk No Command Id	No command ID contained in the command file.

Code	Message	Description
255	IA Invalid Data	Invalid image address data.
256	IA Field Overflow	Image address field overflow. Need to increase size of field for image address within the Film Template definition for this application.
257	IA Format Width	Image address field too wide.
258	IA Format Length	Image address length too long.
259	IA Format Definition	
260	IA Format Number	Invalid number of address fields.
261	IA Nonsequential Address	
262	Ls Language File Read Error	An error occurred while loading a language file.
263	PD Invalid Powerdown Interval	Invalid power down interval was entered.
264	ST Invalid Time Format	The time parameter entered was in an incompatible format.
#	Message	Explanation
265	ST Invalid Date Format	The date parameter entered was in an incompatible format.
266	CD CP Command Not Allowed Off Line	A command was received from the host that is not valid in the off-line mode.
267	CD CP Command Not Allowed With Critical Error Condition	A command was received after the Writer reported a critical error but before the warning was corrected.
268	CD CP Command Not Allowed With Recoverable Error Condition	A command was received after the reported correctable error but before the warning was corrected.
269	CD CP Command Not Allowed With Warning Error Condition	A command was received after the Writer reported a warning but before the warning was corrected.
270	IC No File Specified	No image file was specified in the print image command. Specify an image file with the print image command.
271	EH IO Image Log Size Exceeded	The image log file is at its maximum size. Rename the log file; remove the old log file.
272	EH NET Cant Add Host	Could not add a host to the Host table that exists. Check the command file being used for Set Network Specification and make sure it contains a valid host name and host IP address.
273	FD Verify Film Upper Cassette	This error can occur if NV RAM in film cassette is reinitialized or if film cassette is left too long with a battery in it. To resolve this, run a small job through the AWIS Application will reinitialize the cassette's memory. A cassette is inserted in the upper film bay of the Writer that has not been previously used in an Writer. It is possible that the cassette is an IL30/70 cassette. Verify the cassette inserted in the upper film bay is the proper cassette.
274	FD Verify Film Lower Cassette	A cassette is inserted in the lower film bay of the Writer that has not been previously used in an Writer. It is possible that the cassette is an IL30/70 cassette. Verify the cassette inserted in the lower film bay is the proper cassette.

Code	Message	Description
276	CC II IMC Required Before Printing	The host is attempting to print a job with IMC enabled before sending the Writer IMC parameters and 'make IMC' command. Command the Writer to write IMC via the host application.
277	EH IC Type Invalid	An invalid film format was received from the host. Simplex or duplex should be specified.
278	EH IC Scaling Invalid	An invalid image scaling value was received from the host.
279	EH IC Origin Invalid	An invalid image origin was received from the host.
280	IA Invalid Level	An attempt to set the image level to an invalid value occurred. The value must be between 0 and x. Where x is the number of image levels used.
290	EH FT Transfer Timed Out	Failed to receive data packet before watchdog timed out.
298	FD 5 Meter Warning	The film remaining in the upper cassette is equal to or less than 5 meters.
299	FD 3 Meter Warning	The film remaining in the upper cassette is equal to or less than 3 meters.
300	CD CP Command Substitution Error	Command Decoder: command being over-written.
301	CD CP Initialization Error	Command Processor: initialization error.
302	CD CP MsgQ Receive Error	Command Processor: error getting message from queue.
303	CD CP MsgQ Time Out Error	Timeout occurred waiting for message from queue.
304	CD CP Invalid MsgQ Return Code	Unknown return code received for messageGet.
305	CD CP Executing Uninitialized Command	Command Processor: command function not initialized.
306	CD CP Error Checking Uninitialized	Command Processor: error checking function not initialized.
307	CD CP Command Element Init Invalid Index	Index is not within the list of functions.
308	CD CP Invalid Param Components Length	Command parameter length exceeds CD message size.
309	FD Msg Init Data Length Error	Initializing a film drive message with data longer than the buffer size.
311	FD Cassette Data Release Failed	Cassette data semaphore. Give failed.
312	FD Cassette Data Illegal Cassette Id	Cassette index is out of range.
313	FD Cassette Status Reservation Failed	Cassette status semaphore. Take failed.
314	FD Cassette Status Release Failed	Cassette status semaphore. Give failed.
315	FD Cassette Status Illegal Cassette Id	Cassette index out of range.
316	FD Message Send Error	Error sending to message queue.
317	FD CP Initialization Error	Film Drive Command Processor Task initialization error.
318	FD CP MsgQ Receive Error	Film Drive Command Processor error getting message from queue.
319	FD CP Cmd Time Out Error	Command response timer timed-out.

Code	Message	Description
320	FD CP Illegal FD State Error	Film Drive Command Processor is in an illegal state.
322	FD CP Invalid MsgQ Return Code	Application Message Queue message. Get returned an invalid status.
323	FD CP Cmd Check Array Full	No room in the queue for the current command's response parameters (command ID; requesters ID; response required; and response timeout).
324	Received Invalid Message	From FDS. The command terminator received does not match one of the valid commands in the film drive.
325	FD RH Receive Buffer Overrun	The film drive servo sent a message longer than the embedded controller's receive buffer.
326	Film Drive Serial Port Read Error	Embedded Controller error reading a character from the serial port.
327	FD RH MsgQ Send Error	Film Drive Response Handler task reported an error sending a message to a message queue.
328	EH WRIB DOS Reserve Failed	WRIB error: DOS reserve failed.
329	EH WRIB DOS Release Failed	WRIB error: DOS release failed.
330	EH WRIB File Read Error	WRIB error: DOS file read error.
331	EH WRIB Unknown Decompress Unblock	WRIB error: Unknown semaphore unblock reason.
332	EH WRIB Memory Reservation Failed	WRIB error: memory semaphore take.
333	EH WRIB Memory Release Failed	WRIB error: memory semaphore give.
334	EH WRIB Ram Frame Malloc Failure	WRIB error: RAM memory malloc failure.
335	EH WRIB Max Images Per Frame Exceeded	WRIB frame failure: maximum images per frame exceeded.
336	EH WRIB Frame Malloc Failure	WRIB error: memory malloc failure.
337	EH WRIB Invalid Image Index	WRIB error: image index invalid.
338	EH WRIB Frame Not Found In WRIB Memory	WRIB memory warning: frame to delete not found.
339	EH IO MsgQ Length Too Small	Image Output message queue length too small.
341	EH IO Image Log Open Error	Image Output log open failure, file could not be opened.
342	EH IO Image Log Close Error	Image Output log close failure, file could not be closed.
343	EH IO Image Log Write Error	Image Output log write failure, write error.
344	EH IO Initialization Error	Image Output initialization error.
345	EH IO MsgQ Send Error	Image Output message queue send error.
346	EH IO MsgQ Receive Error	Image Output message queue receive error.
347	EH IO MsgQ Time Out Error	Image Output message queue timeout error.
348	EH IO Invalid MsgQ Return Code	Image Output invalid message queue return value.
353	EH IO IA String Too Long	Image Output frame image address string is too long.
354	EH IO Filename Too Long	Image Output frame image filename string is too long.
355	EH IO Too Many Image Files	Image Output frame contains too many image files.
356	EH IO Framemessage Retrieve Index	Image Output invalid frame message index.
357	CC II Memory Allocation Error	Image Input: memory allocation failure.
358	CC II Disk Reserve Error	Disk reserve semaphore take error.

Code	Message	Description
359	EH IC MsgQ Send Error	Image Composition message queue send error.
360	EH IC Initialization Error	Image Composition initialization failure.
361	EH IC MsgQ Receive Error	Image Composition message queue receive error.
362	EH IC MsgQ Time Out Error	Image Composition message queue time-out error.
363	EH IC Invalid MsgQ Return Code	Image Composition invalid message queue return code.
364	EH IC Unknown Message Command	Image Composition unknown message command.
365	EH IC MsgQ Length Too Small	Image Composition message queue length too small.
366	EH IC Unknown Scaling Type	Image Composition unknown image scaling type.
367	EH IC Overlapping Frame Images	Image Composition overlapping images in frame.
368	EH IC DOS Reserve Failed	Image Composition DOS reserve failed.
369	EH IC DOS Release Failed	Image Composition DOS release failed.
370	EH IC File Delete Error	Image Composition image file delete error.
372	EH IC Too Many Images In Frame	Image Composition has too many images in the frame.
373	EH IC Trying To Insert Too Many Images Into Frame	Image Composition trying to insert too many images into frame.
374	EH IC Invalid Blip Request	Image Composition invalid blip type.
375	EH IC Memory Allocation Error	Image Composition memory allocation error.
376	EH IC Invalid Blip Level	Image Composition invalid blip index level.
379	EH DOS Disk Message Received No Transaction Active	Host application interface manager received a response from the Writer when a command was not being processed.
380	EH DOS Disk Error In Retrieving Message	Host application interface manager error is receiving message from queue.
381	EH DOS Disk Response Not Received In Time	Host application interface manager error is not receiving response from system to a command within a specified period of time.
382	EH DOS Disk Invalid MsgQ Return Code	Host application interface manager unknown status in receiving from message queue.
383	EH DOS Disk Failed To Create Directories	Cannot create the DOS file system directories.
384	EH DOS Disk Failed To Create Disk	Cannot reserve the DOS file system.
386	EH DOS Disk Disk Reservation Failed	Cannot reserve the DOS file system; cannot take semaphore protecting the file system.
387	EH DOS Disk Disk Release Failed	Cannot release the DOS file system; cannot give semaphore protecting the file system.
388	EH SCSI Invalid Script Inst Int	Invalid instruction reported from SCSI I/O controller.
389	EH SCSI Invalid Script Entry Calculated	Internal programming error; could not determine what instruction the SCSI I/O controller should execute next.
390	EH SCSI Message Receive Error	SCSI target driver error in receiving message from queue.
391	EH SCSI Invalid Script Entry Requested	Internal programming error; determined an instruction for the SCSI I/O controller to execute that is not a valid instruction.

Code	Message	Description
392	EH SCSI Invalid Script Inst Int Read	Invalid SCSI I/O processor instruction reported from the I/O processor.
394	EH Error Index Out Of Range	Error handler index out of range.
396	EH Negative Index	Cannot process negative index.
397	IA Sem Take Failed	Error entering IA critical region.
398	IA Sem Give Failed	Error exiting IA critical region.
399	IA Mem Alloc Failed	Unable to allocate memory for IA field.
403	CD MsgQ Send Error	Error sending to message queue.
404	CD Msg Data Length Error	Messaged data is longer than the message buffer size.
406	SCSI Error	
414	CC IMC Annotate Fail	
415	OI MsgQ Send Error	Error sending message to queue.
417	OI Window Invalid Index	Window index is larger than the number of declared windows.
418	OI State Invalid State	Key state received is larger than the number of declared states.
419	OI State Invalid Key	Key index received is larger than the number of declared keys.
420	OI MP Initialization Error	OI message processor initialization error.
421	OI MP MsgQ Receive Error	OI message processor error getting message from queue.
422	OI MP MsgQ Time Out Error	OI message processor timeout occurred waiting for message from queue.
423	OI MP Invalid MsgQ Return Code	
424	UI MsgQ Receive Error	UI send: error getting message from queue.
425	UI MsgQ Time Out Error	UI send: timeout occurred waiting for message from queue.
426	UI Invalid MsgQ Return Code	UI send: unknown return code received from messageGet.
427	UI Send Time Out Error	UI send: timeout waiting for command response from the UI.
428	UI MsgQ Send Error	Error sending message to queue.
429	UI Receive Initialization Error	Receive task initialization error.
430	UI Serial Port Read Error	Embedded controller error reading the UI serial port.
431	UI Receive Invalid Key Code	Receive unknown key code from the user interface.
432	CC OI Param Data1 Not Found	Parameter data not found in the message received.
433	CC OI Param Data2 Not Found	Parameter data not found in the message received.
434	CC OI Param Data3 Not Found	Parameter data not found in the message received.
435	CC OI Param Data4 Not Found	Parameter data not found in the message received.
436	CC OI Param Data5 Not Found	Parameter data not found in the message received.
437	CC OI Param Data6 Not Found	Parameter data not found in the message received.
438	EH Memory Malloc Error	Error log memory malloc failed.

Code	Message	Description
440	EH IO No File To Append Image Log Entry	
441	EH System Startup Failed	
442	EH Sys Config File Release Failed	
443	EH Sys Config File Reserve Failed	
444	EH Set Environment Failed	
445	EH WRIB Invalid Operating Parameters	
449	IC Memory Malloc Error Struct	The image parameter data structure could not be created.
450	IC Memory Malloc Error Field	The image parameter data field could not be created. Call service.
451	PD Sem Give Failure	Unable to give semaphore to indicate system activity.
452	EH NET Cant Add Gateway	Could not add a gateway to the Gateway table that exists in the gateway destination list. Call service.
453	EH NET Cant Create Nfsdaemon	Failure of nfsdInit within NetworkInitializationManager. Call service.
454	EH NET Cant Export Filesystem	Failure of nfsExport within NetworkInitializationManager. Call service.
455	ST Unable To Read System Clock	The embedded firmware could not read/set the system clock. An error was returned from one of the system time/date routines. Call service.
456	ST Unable To Set System Clock	The embedded firmware could not read/set the system clock. An error was returned from one of the system time/date routines. Call service.
457	ST Unable To Set System Time	The embedded firmware could not read/set the system clock. An error was returned from one of the system time/date routines. Call service.
458	ST Unable To Set System Date	The embedded firmware could not read/set the system clock. An error was returned from one of the system time/date routines. Call service.
459	Diagnostic Serial Port Read Error	Diagnostic serial port read error.
460	LT MP Initialization Error	LT MP Initialization error.
461	LT MP MsgQ Receive Error	LT MP MSGQ receive error.
462	LT MP Invalid MsgQ Return Code	MP invalid MSGQ return error.
463	LT App Data Recv Error	LT APP data receive error.
464	LT App Data Recv Invalid MsgQ Return Code	LT APP data invalid MSGQ return code.
465	LT MP Unknown Scc Request	LT MP unknown SCC request.
466	LT MsgQ Send Error	LT MP MSGQ send error.
467	LT MP Cmd Time Out	LT MP CMD timeout.
468	LT MP Unknown Scc Msg 55 Prog Num	LT MP unknown MSG 55 program number.

Code	Message	Description
469	LT MP Unknown Scc Msg 52 Data Type	LT MP unknown MSG 52 data type.
470	EH Aim Reservation Failed	Unable to take AIM semaphore.
471	EH Aim Release Failed	Unable to release AIM semaphore.
472	EH DOS Disk Expected Priority Transaction	Writer is expecting a priority transaction and host sent normal transaction.
473	EH Transaction Already Active	The host tried to initiate a command using a transaction number of a currently active transaction.
474	EH Aimend Couldnt Signify Transaction Completion	Writer lost communication with host.
475	EH NET Cant Initialize Gateways	Failure to add gateway to Gateway table. Call service.
476	EH NET Cant Create Socket	Failure to create socket. Call service.
477	EH NET Cant Accept Transactions	Failure to accept connection on the input or output socket. Call service.
478	EH NET Cant Read In Socket	Failure to read from the input socket. Call service.
479	EH NET Cant Write Out Socket	Failure to write to the output socket. Call service.
480	EH II Too Many Image FDS	
481	EH FT Cant Transfer File	
700	EH WRIB Unexpected Pm2 Status Change	WRIB PM2 unexpected status.
701	EH WRIB Unexpected Image Decompression Done	WRIB unexpected Image Decompression Done.
702	EH WRIB Unknown WRIB Interrupt	WRIB unknown interrupt.
703	EH WRIB Unexpected Image Print Error	WRIB unexpected Image Print Error.
704	EH WRIB Unexpected Input FIFO Half Full	WRIB unexpected input FIFO half full.
705	EH WRIB No Images In Frame	WRIB unexpected input FIFO half full.
706	EH WRIB Memory Full Too Long memory full	WRIB download failure.
707	EH WRIB Frame Too Large	WRIB download failure: frame dimensions outside limits.
708	EH WRIB Unknown Memory Full Exception	WRIB error: invalid memory result.
709	EH WRIB Download Unknown Status Change	WRIB error: unknown download status change.
710	EH WRIB Image Download Timeout	WRIB download failure: image download timeout.
711	EH WRIB Image Decompression Timeout	WRIB download failure: image decompression timeout.
712	EH WRIB Image Decompression Failure	WRIB download failure: image decompression failure.
713	EH WRIB FIFO Full Timeout	WRIB download failure: FIFO full timeout.
714	EH WRIB Pm2 Status Error	WRIB download failure: PM2 status error.
715	EH WRIB Unknown Decompress Exception	WRIB error: decompress exception.

Code	Message	Description
716	EH WRIB Unknown FIFO Exception	WRIB error: FIFO exception.
717	EH WRIB Unknown Retry Error	WRIB error: retry error.
718	EH WRIB Output Unknown Status Change	WRIB error: frame output unknown status change.
719	EH IO Frame Print Timeout	Image Output failure: frame printing timeout.
720	EH IO WRIB Print Error	Image Output failure: WRIB print error.
721	Id Invalid Film Remaining Flag	
722	EH IC Annotation String Truncated	
901	FD Motor Failure	1700 board hardware motor failure. The error is reported if any of the motor voltage; current; or speed signals.
902	FD Invalid Command Received	Unknown or unimplemented command received by film drive servo from the embedded controller.
903	FD Counter Oscillator Error	1700 board hardware failure.
904	FD Aper Encoder Error	1700 board hardware failure.
905	FD Freq Multiplier Error	1700 board hardware failure.
906	FD Servo Feedback Encdr Err	1700 board hardware failure.
907	FD Servo Amplifier Error	1700 board hardware failure.
908	FD Micro Controller Error	1700 board hardware failure.
909	FD Aper Source Switch Error	1700 board hardware failure.
910	FD Stop After Source Switch	1700 board hardware failure.
911	FD Diag Switches On	The 1700 PCB's dip switch pack S2 switch 1 has been moved to the On position.
912	FD Upper Supply Ecndr Error	1700 board hardware failure.
913	FD Lower Supply Ecndr Error	1700 board hardware failure.
914	FD Freq Multiplier Error	1700 board hardware failure.
915	FD Shutter Failed To Open	The shutter did not open within the specified time interval.
916	FD Shutter Failed To Close	The shutter did not close within the specified time interval.
917	FD Async Shutter Change	Unexpected change in the shutter position.
918	FD Invalid M Value	An invalid motor speed setting was sent to the film drive servo.
919	FD Cassette Data Update Error	A cassette reported an error with the data sent by the film drive servo. The problem could be caused by a weak battery in the cassette or a dirty IR transmitter or receiver. Replace the cassette battery. If the problem persists, call Service.
920	FD Servo Reset	Either the Reset button was pressed, the film drive servo reset due to loss of power, or a hardware error occurred.
921	Received Unknown Async Error From FDS	1700 board hardware/software error.
922	EH DOS Disk Command File Close Failed	Cannot close command file.

Code	Message	Description
923	EH DOS Disk Status File Write Failed	Cannot write status file.
924	EH DOS Disk Response File Write Failed	Cannot write response to a file.
925	EH DOS Disk Command File Delete Failed	Cannot delete command file.
927	EH SCSI Invalid Dma Status	Invalid status reported from SCSI I/O controller.
928	EH SCSI Unknown Dma Status	Unknown status reported from SCSI I/O controller.
929	EH SCSI Invalid SCSI Status	Invalid status reported from SCSI I/O controller.
930	EH Aimstart MsgQ Retrieve Error	
931	EH Aimstart MsgQ Send Error	Could not add a host to the Host table that exists on the boot line.
933	EH Aimwd Cannot Start Watchdog	
934	EH Aimwd Cannot Stop Watchdog	
935	EH Aimwd Reservation Failed	
936	EH Aimwd Release Failed	
937	EH Aimwd Cannot Give Timeout Semaphore	
938	FTP Buffer Malloc Failed	
939	FTP Connection Failed	
940	FTP Data Malloc Failed	
941	FTP Transfer Failed	
942	FTP Local File Create Failed	
943	EH Cant Create FT Daemon	
944	EH Cant Delete FT Daemon	
945	EH Cant Create FT Watchdog	
946	EH Cant Delete FT Watchdog	
947	EH FT Cant Close File	
948	EH FT Cant Delete File	
949	EH FT Cant Start Transfer Timer	
950	EH FT Cant Stop Transfer Timer	

Appendix A Input Modes

Input modes

AWIS reads image files from a disk drive (usually a drive that is shared on the network) and sends them to the Writer. Input modes allow you to sequence image files as desired on film. Following are the supported input modes:

- Batch
- List file
- Poll

Batch and List file are described in this section. For more information about Poll mode, see the section entitled, “File Menu - Options” in Chapter 3.

Batch

In this mode, image files are read from a directory specified via the AWIS Administration software. The presence of subdirectories and the number of subdirectory levels, in conjunction with film mode and level rules, determines the sequencing of images on film at the desired level. The sequencing of images within a level is done via the Windows file sorting algorithm. The directory structure required to provide the desired results on film is dependent on input file type (single-page or multi-page TIFF).

- For **single-level** indexing with single-page or multi-page TIFF files, the directory must contain only the TIFF files and no subdirectories. (See Examples 1 and 4 in this section.)

NOTE: With multi-page TIFF files the multi-page grouping will be lost.

- For **two-level** indexing with single-page TIFF files, the directory must contain one or more subdirectories one level down, each of which contains TIFF files. Within each subdirectory, the first image (simplex mode) or first two images (duplex mode) will be written as level 2, and subsequent images will be written as level 1. (See Example 5 in this section.)
- For **two-level** indexing with multi-page TIFF files, the directory must contain only the TIFF files and no subdirectories. The first image (simplex mode) or first two images (duplex mode) of each file will be written as level 2, and subsequent images will be written as level 1. If single-page files are included, they are processed as multi-page files with only one page and written as level 2. (See Example 9 in this section.)

- For **three-level** indexing with single-page TIFF files, the directory must contain one or more subdirectories one level down, each of which contains one or more subdirectories that contain TIFF files. For the first sub-subdirectory within each subdirectory, the first image (simplex mode) or first two images (duplex mode) will be written as level 3, the next image (simplex mode) or next two images (duplex mode) will be written as level 2, and subsequent images will be written as level 1. For all subsequent sub-subdirectories within each subdirectory, the first image (simplex mode) or first two images (duplex mode) will be written as level 2 and subsequent images will be written as level 1. (See Example 6 in this section.)
- For three-level indexing with multi-page TIFF files, the directory must contain one or more subdirectories one level down, each of which contains TIFF files. For the first file within each subdirectory, the first image (simplex mode) or first two images (duplex mode) will be written as level 3, the next image (simplex mode) or next two images (duplex mode) will be written as level 2, and subsequent images will be written as level 1. For all subsequent files within each subdirectory, the first image (simplex mode) or first two images (duplex mode) will be written as level 2 and subsequent images will be written as level 1. (See Examples 8 and 10 in this section.)

NOTES:

- Level 0 images are not supported with Batch input mode.
- If film mode is duplex and the index format is 2-level or 3-level, the B channel will be left blank in any frame where a higher-level image follows the A channel image, or where a level 3 or level 2 image follows a level 3 or level 2 images.

List file

In this mode, the image files to be written to film must be listed in a file using full pathnames. Files are read and written to film in the same order as they appear in the List file.

Image levels are specified with the use of one or more dashes. A pathname not preceded with a dash(es) specifies the highest level per the index format. Each dash preceding a pathname represents one image level below the highest level.

NOTE: With 2- or 3-level indexing the first pathname in the List file must be specified at the highest level, or level 0.

The List file structure required to provide the desired results on film is dependent on input file type (single-page or multi-page TIFF).

- For single-level indexing with **single-page** or **multi-page** TIFF files, the maximum number of dashes that can precede a pathname is 1. Pathnames with no dash result in level 1 images, and pathnames with 1 dash result in level 0 images. (See Examples 1 and 4 in this section.)

NOTE: With multi-page TIFF files the multi-page grouping will be lost.

- For two-level indexing with **single-page** TIFF files, the maximum number of dashes that can precede a pathname is 2. Pathnames with no dash result in level 2 images, pathnames with 1 dash result in level 1 images, and pathnames with 2 dashes result in level 0 images. When film mode is duplex, each level 2 file, that is followed by a level 1 file, will be paired with that level 1 file and both will be written as level 2. All subsequent files, until the next level 2 designation, will be written as level 1. (See Examples 2 and 5 in this section.)
- For two-level indexing with **multi-page** TIFF files, the maximum number of dashes that can precede a pathname is 2. A pathname with no dashes results in the first image (simplex mode) or first two images (duplex mode) of the file being written as level 2, and subsequent images being written as level 1. A pathname with 1 dash results in all images of the file being written as level 1. A pathname with 2 dashes results in all images of the file being written as level 0. (See Examples 7 and 9 in this section.)

NOTE: The inclusion of dashes with multi-page files will cause the multi-page grouping to be rearranged since the files will be written as pages of the preceding level 2 file.

- For three-level indexing with **single-page** TIFF files, the maximum number of dashes that can precede a pathname is 3. Pathnames with no dash result in level 3 images, pathnames with 1 dash result in level 2 images, pathnames with 2 dashes result in level 1 images, and pathnames with 3 dashes result in level 0 images. When film mode is duplex, each level 3 file will be alone in a frame in the A channel, and each level 2 file, that is followed by a level 1 file, will be paired with that level 1 file and both will be written as level 2. All subsequent files, until the next level 3 or 2 designation, will be written as level 1. (See Example 3 in this section.)
- For three-level indexing with multi-page TIFF files, the maximum number of dashes that can precede a pathname is 3. A pathname with no dashes results in the first image (simplex mode) or first two images (duplex mode) of the file being written as level 3, the next image (simplex mode) or next two images (duplex mode) being written as level 2, and subsequent images being written as level 1. A pathname with one dash results in the first image (simplex mode) or first two images (duplex mode) of the file being written as level 2, and subsequent images being written as level 1. A pathname with 3 dashes results in all images of the file being written as level 1. A pathname with 3 dashes results in all images of the file being written as level 0. (See Examples 8 and 10 in this section.)

NOTES:

- Use of level 0 should be limited and is not recommended since the images cannot be retrieved with automatic methods.
- If film mode is duplex and the index format is 2-level or 3-level, the B channel will be left blank in any frame where a higher-level image follows the A channel image, or where a level 3 or level 2 image follows a level 3 or level 2 image.

Creating a List file

List files can be created using a text editor or customer-defined program. List file creation is not part of AWIS.

List files must conform to the following specifications:

- Must end with a .txt filename extension.
- A separate line must be used for each image file.
- Each line must include the full pathname of the file, and the .tif file extension.
- Every line should start at column 0.
- A line cannot start with a space.
- Image level changes are specified by prefixing the full pathname of a file with dashes. For more information, see the previous section entitled, "List file".
- No spaces are allowed between the dash(es) (denoting a level change) and the pathname.

NOTE: Use of level 0 should be limited and is not recommended since the images cannot be retrieved with automatic methods.

Examples

The following examples illustrate most requirements for archiving. The examples provide summaries of application and film template setup, demonstrate the use of default level rules, show sample batch and list file input, and graphically depict the resultant film.

Example 1

Application Setup

Index Format: Single-level (no grouping)
Image Type: Single-page TIFF files
Film Mode: Simplex
Starting Image Address: XYZ.00001
Input Mode: List or Batch

Batch Directory



List file

c:\images\sptif01.tif
c:\images\sptif02.tif
c:\images\sptif03.tif

Image File	Image Address	
c:\images\sptif01.tif	XYZ.00001	
c:\images\sptif02.tif	XYZ.00002	
c:\images\sptif03.tif	XYZ.00003	

Example 2

Application Setup

Index Format: 2-level (for grouping)
Image Type: Single-page TIFF
Film Mode: Simplex
Starting Image Address: FIX.001.000
Input Mode: List

List file

Level	List file
2	c:\smith\sptif01.tif
1	-c:\smith\sptif02.tif
2	c:\jones\sptif01.tif
1	-c:\jones\sptif02.tif
1	-c:\jones\sptif03.tif
2	d:\acct\sptif01.tif
2	d:\deed\sptif01.tif
1	-d:\deed\sptif02.tif
1	-d:\deed\sptif03.tif

Image File	Image Address
------------	---------------

c:\smith\sptif01.tif	FIX.001.000
-c:\smith\sptif02.tif	FIX.001.001
c:\jones\sptif01.tif	FIX.002.000
-c:\jones\sptif02.tif	FIX.002.001
-c:\jones\sptif03.tif	FIX.002.002
d:\acct\sptif01.tif	FIX.003.000
d:\deed\sptif01.tif	FIX.004.000
-d:\deed\sptif02.tif	FIX.004.001
-d:\deed\sptif03.tif	FIX.004.002

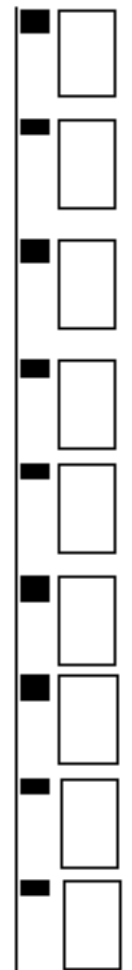













Example 3

Application Setup

Index Format: 3-level (for grouping)
Image Type: Single-page TIFF
Film Mode: Simplex
Starting Image Address: FIX.001.000.000
Input Mode: List

List File

Level	List file
3	c:\acct3\jones\spjones01.tif
2	-c:\acct3\jones\spjones02.tif
1	--c:\acct3\jones\spjones03.tif
2	-c:\acct3\smith\spsmith01.tif
2	-c:\acct3\elm\spelms01.tif
1	--c:\acct3\elm\spelms02.tif
3	d:\deeds\1900\1920\sp01.tif
2	-d:\deeds\1900\1920\sp02.tif
1	--d:\deeds\1900\1920\sp03.tif
1	--d:\deeds\1900\1920\sp04.tif
2	-d:\deeds\1900\1921\sp01.tif
1	--d:\deeds\1900\1921\sp02.tif
1	--d:\deeds\1900\1921\sp03.tif

Image File	Page within Grouping	Image Address	
c:\acct3\jones\spjones01.tif	1	FDX.001.000.000	 <input data-bbox="1367 247 1425 340" type="checkbox"/>
-c:\acct3\jones\spjones02.tif	2	FDX.001.001.000	 <input data-bbox="1367 352 1425 445" type="checkbox"/>
-c:\acct3\jones\spjones03.tif	3	FDX.001.001.001	 <input data-bbox="1367 466 1425 558" type="checkbox"/>
-c:\acct3\harris\sparrish01.tif	1	FDX.001.002.000	 <input data-bbox="1367 588 1425 680" type="checkbox"/>
-c:\acct3\harris\spelm01.tif	1	FDX.001.003.000	 <input data-bbox="1367 701 1425 793" type="checkbox"/>
-c:\acct3\harris\spelm02.tif	2	FDX.001.003.001	 <input data-bbox="1367 814 1425 907" type="checkbox"/>
d:\deeds\1900\1920\sp01.tif	1	FDX.002.000.000	 <input data-bbox="1367 915 1425 1008" type="checkbox"/>
-d:\deeds\1900\1920\sp02.tif	2	FDX.002.001.000	 <input data-bbox="1367 1016 1425 1108" type="checkbox"/>
-d:\deeds\1900\1920\sp03.tif	3	FDX.002.001.001	 <input data-bbox="1367 1117 1425 1209" type="checkbox"/>
-d:\deeds\1900\1920\sp04.tif	4	FDX.002.001.002	 <input data-bbox="1367 1230 1425 1323" type="checkbox"/>
-d:\deeds\1900\1921\sp01.tif	1	FDX.002.002.000	 <input data-bbox="1367 1331 1425 1423" type="checkbox"/>
-d:\deeds\1900\1921\sp02.tif	2	FDX.002.002.001	 <input data-bbox="1367 1436 1425 1528" type="checkbox"/>
-d:\deeds\1900\1921\sp03.tif	3	FDX.002.002.002	 <input data-bbox="1367 1537 1425 1629" type="checkbox"/>

Example 4

Application Setup

Index Format: Single-level (no grouping)
Image Type: Single-page TIFF
Film Mode: Duplex (A and B channels)
Starting Image Address: FIX.001
Input Mode: List or Batch

Batch Directory

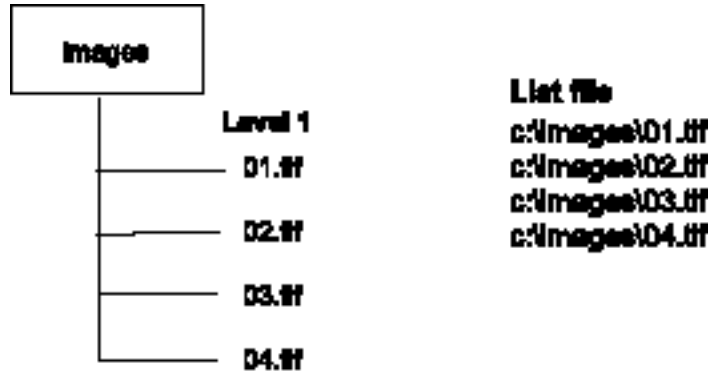

Channel	Image File	Image Address	A	B
A	c:\images\D1.tif	FIX.001	[]	[]
B	c:\images\D2.tif	FIX.001		
A	c:\images\D3.tif	FIX.002	[]	[]
B	c:\images\D4.tif	FIX.002		

NOTE: Duplex mode maximizes the number of images that can be written to one roll of film.

Example 5

Application Setup

Index Format: 2-level (for grouping)
Image Type: Single-page TIFF
Film Mode: Duplex (A and B channel)
Starting Image Address: FIX.001.000
Input Mode: Batch or List

Batch Directory

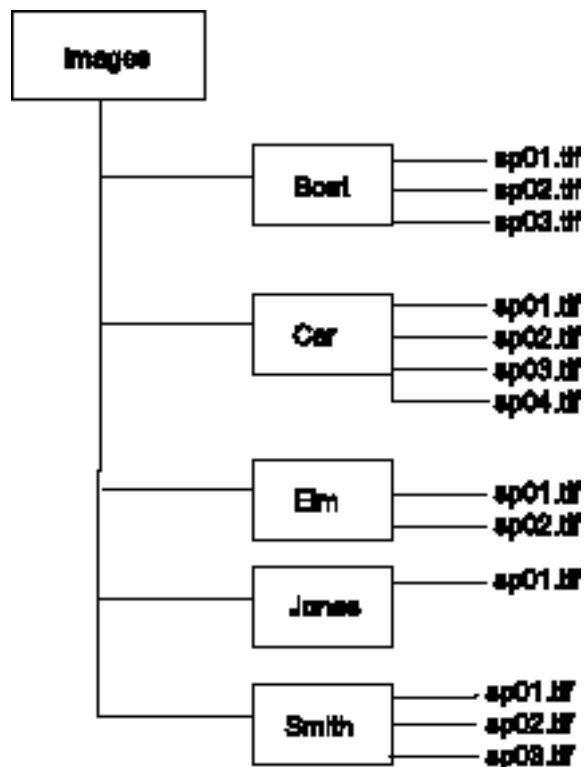

Equivalent List File

Level

```

2      c:\images\boat\sp01.tif
1      -c:\images\boat\sp02.tif
1      -c:\images\boat\sp03.tif
2      c:\images\car\sp01.tif
1      -c:\images\car\sp02.tif
1      -c:\images\car\sp03.tif
1      -c:\images\car\sp04.tif
2      c:\images\elm\sp01.tif
1      -c:\images\elm\sp02.tif
2      c:\images\jones\sp01.tif
2      c:\images\smith\sp01.tif
1      -c:\images\smith\sp02.tif
1      -c:\images\smith\sp03.tif
    
```

List Level	Film Level	Channel	Image File	Page within Grouping	Image Address			
2	2	A	c:\images\boat\sp01.tif	1	FDX.001.000	■		
1	2	B	c:\images\boat\sp02.tif	2	FDX.001.000			
1	1	A	c:\images\boat\sp03.tif	3	FDX.001.001	■		
2	2	A	c:\images\car\sp01.tif	1	FDX.002.000	■		
1	2	B	c:\images\car\sp02.tif	2	FDX.002.000			
1	1	A	c:\images\car\sp03.tif	3	FDX.002.001	■		
1	1	B	c:\images\car\sp04.tif	4	FDX.002.001			
2	2	A	c:\images\elm\sp01.tif	1	FDX.003.000	■		
1	2	B	c:\images\elm\sp02.tif	2	FDX.003.000			
2	2	A	c:\images\jones\sp01.tif	1	FDX.004.000	■		
2	2	A	c:\images\smith\sp01.tif	1	FDX.005.000	■		
1	2	B	c:\images\smith\sp02.tif	2	FDX.005.000			
1	1	A	c:\images\smith\sp03.tif	3	FDX.005.001	■		

NOTE: Duplex mode overrides the list file level designation within a grouping. This allows the grouping to be maintained while maximizing the number of images that can be written to one roll of film.

Example 6

Application Setup

Index Format: 3-level (for grouping)
Image Type: Single-page TIFF
Film Mode: Duplex (A and B channel)
Starting Image Address: FIX.001.000.000
Input Mode: Batch

Batch Directory

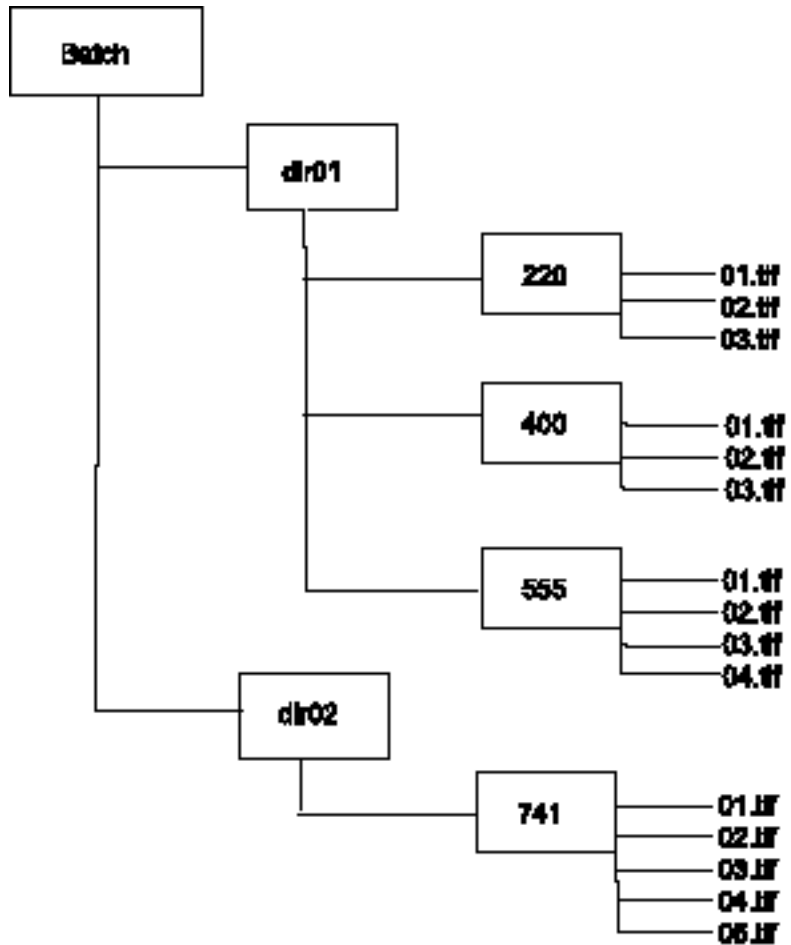

List Level	File Level	Channel	Image File	Image Address		
3	3	A	c:\Bata\hdir\01\220\01.tif	FDX.001.000.000	■	<input type="checkbox"/>
2	3	B	c:\Bata\hdir\01\220\02.tif	FDX.001.000.000		<input type="checkbox"/>
1	2	A	c:\Bata\hdir\01\220\03.tif	FDX.001.001.001	■	<input type="checkbox"/>
2	2	A	c:\Bata\hdir\01\400\01.tif	FDX.001.002.000	■	<input type="checkbox"/>
1	2	B	c:\Bata\hdir\01\400\02.tif	FDX.001.002.000		<input type="checkbox"/>
1	1	A	c:\Bata\hdir\01\400\03.tif	FDX.001.002.001	■	<input type="checkbox"/>
2	2	A	c:\Bata\hdir\01\666\01.tif	FDX.001.008.000	■	<input type="checkbox"/>
1	2	B	c:\Bata\hdir\01\666\02.tif	FDX.001.008.000		<input type="checkbox"/>
1	1	A	c:\Bata\hdir\01\666\03.tif	FDX.001.008.001	■	<input type="checkbox"/>
1	1	B	c:\Bata\hdir\01\666\04.tif	FDX.001.008.001		<input type="checkbox"/>
3	3	A	c:\Bata\hdir\02\741\01.tif	FDX.002.000.000	■	<input type="checkbox"/>
2	3	B	c:\Bata\hdir\02\741\02.tif	FDX.002.000.000		<input type="checkbox"/>
1	2	A	c:\Bata\hdir\02\741\03.tif	FDX.002.001.000	■	<input type="checkbox"/>
1	2	B	c:\Bata\hdir\02\741\04.tif	FDX.002.001.000		<input type="checkbox"/>
1	1	A	c:\Bata\hdir\02\741\05.tif	FDX.002.001.001	■	<input type="checkbox"/>

Example 7

Application Setup

Index Format: 2-level (for grouping)
Image Type: Multi-page TIFF (2-level grouping)
Film Mode: Simplex
Starting Image Address: FIX.001.000
Input Mode: List

List File

c:\images\2mp.tif
c:\images\3mp.tif
c:\images\1mp.tif
c:\images\4mp.tif

Image File	Page within Image File	Image Address	
c:\images\2mp.tif	1	FIX.001.000	
c:\images\2mp.tif	2	FIX.001.001	
c:\images\3mp.tif	1	FIX.002.000	
c:\images\3mp.tif	2	FIX.002.001	
c:\images\3mp.tif	3	FIX.002.002	
c:\images\1mp.tif	1	FIX.003.000	
c:\images\4mp.tif	1	FIX.004.000	
c:\images\4mp.tif	2	FIX.004.001	
c:\images\4mp.tif	3	FIX.004.002	
c:\images\4mp.tif	4	FIX.004.003	

Example 8

Application Setup

Index Format: 3-level (for grouping)
Image Type: Multi-page TIFF
Film Mode: Simplex
Starting Image Address: FIX.001.000.000
Input Mode: Batch or List

Batch Directory

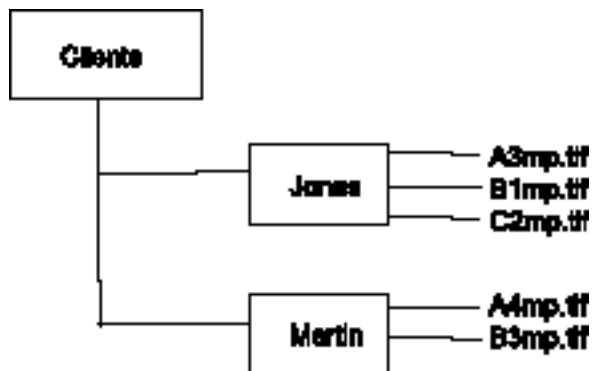

Equivalent List File

- c:\clients\Jones\A3mp.tif
- c:\clients\Jones\B1mp.tif
- c:\images\Jones\C2mp.tif
- c:\clients\Martin\A4mp.tif
- c:\clients\Martin\B3mp.tif

Image File	Page within Image File	Image Address
c:\clients\Jones\A3mp.tif	1	FDX.001.000.000
c:\clients\Jones\A3mp.tif	2	FDX.001.001.000
c:\clients\Jones\A3mp.tif	3	FDX.001.001.001
-c:\clients\Jones\B1mp.tif	1	FDX.001.002.000
-c:\clients\Jones\C2mp.tif	1	FDX.001.003.000
c:\clients\Jones\C2mp.tif	2	FDX.001.003.001
c:\clients\Martin\A4mp.tif	1	FDX.002.000.000
c:\clients\Martin\A4mp.tif	2	FDX.002.001.000
c:\clients\Martin\A4mp.tif	3	FDX.002.001.001
c:\clients\Martin\A4mp.tif	4	FDX.002.001.002
-c:\clients\Martin\B3mp.tif	1	FDX.002.002.000
c:\clients\Martin\B3mp.tif	2	FDX.002.002.001
c:\clients\Martin\B3mp.tif	3	FDX.002.002.002

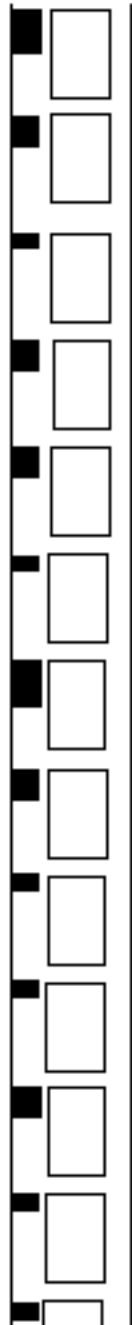

Example 9

Application Setup

Index Format: 2-level (grouping)
Image Type: Multi-page TIFF (2-level grouping)
Film Mode: Duplex (A and B channel)
Starting Image Address: FIX.001.000
Input Mode: Batch or List

Batch Directory

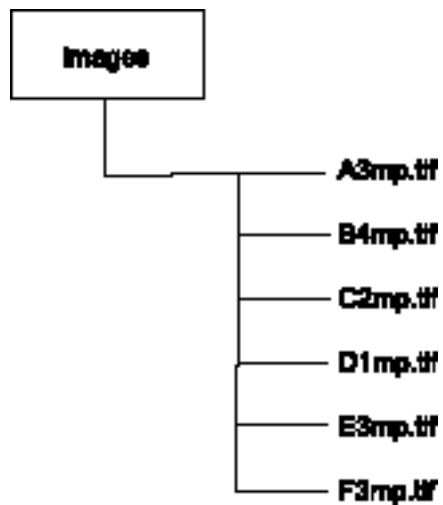

List File

c:\images\A3mp.tif
 c:\images\B4mp.tif
 c:\images\C2mp.tif
 c:\images\D1mp.tif
 c:\images\E3mp.tif
 c:\images\F3mp.tif

Film Level	Channel	Image File	Page within Image File	Image Address		
2	A	c:\images\A3mp.tif	1	FIX.001.000	■	
2	B	c:\images\A3mp.tif	2	FIX.001.000		
1	A	c:\images\A3mp.tif	3	FIX.001.001	■	
2	A	c:\images\B4mp.tif	1	FIX.002.000	■	
2	B	c:\images\B4mp.tif	2	FIX.002.000		
1	A	c:\images\B4mp.tif	3	FIX.002.001	■	
1	B	c:\images\B4mp.tif	4	FIX.002.001		
2	A	c:\images\C2mp.tif	1	FIX.003.000	■	
2	B	c:\images\C2mp.tif	2	FIX.003.000		
2	A	c:\images\D1mp.tif	1	FIX.004.000	■	
2	A	c:\images\E3mp.tif	1	FIX.005.000	■	
2	B	c:\images\E3mp.tif	2	FIX.005.000		
1	A	c:\images\E3mp.tif	3	FIX.005.001	■	
2	A	c:\images\F3mp.tif	1	FIX.006.000	■	
2	B	c:\images\F3mp.tif	2	FIX.006.000		
1	A	c:\images\F3mp.tif	3	FIX.006.001	■	

Example 10

Application Setup

Index Format: 3-level (for grouping)
Image Type: Multi-page TIFF
Film Mode: Duplex
Starting Image Address: FIX.001.000.000
Input Mode: Batch or List

Batch Directory

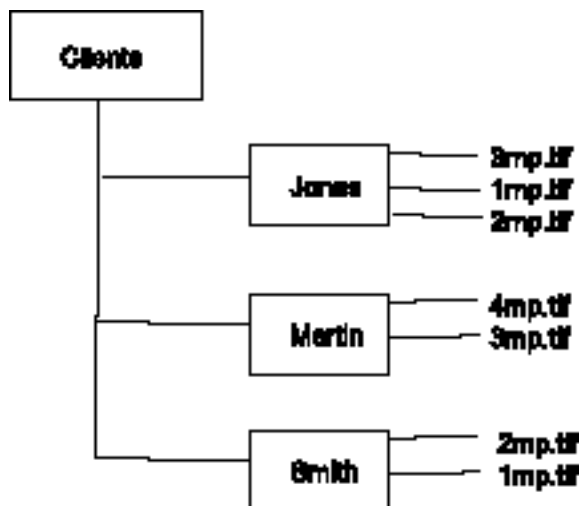

List File

c:\clients\Jones\3mp.tif
 -c:\clients\Jones\1mp.tif
 -c:\clients\Jones\2mp.tif
 c:\clients\Martin\4mp.tif
 -c:\clients\Martin\3mp.tif
 c:\clients\Smith\2mp.tif
 -c:\clients\Smith\1mp.tif.

Film Level	Channel	Image File	Page within Image File	Image Address			
3	A	c:\clients\Jones\3mp.tif	1	FIX.001.000.000	■		
3	B	c:\clients\Jones\3mp.tif	2	FIX.001.000.000			
2	A	c:\clients\Jones\3mp.tif	3	FIX.001.001.000	■		
2	A	c:\clients\Jones\1mp.tif	1	FIX.001.002.000	■		
2	A	c:\clients\Jones\2mp.tif	1	FIX.001.003.000	■		
2	B	c:\clients\Jones\2mp.tif	2	FIX.001.003.000			
3	A	c:\clients\Martin\4mp.tif	1	FIX.002.000.000	■		
3	B	c:\clients\Martin\4mp.tif	2	FIX.002.000.000			
2	A	c:\clients\Martin\4mp.tif	3	FIX.002.001.000	■		
2	B	c:\clients\Martin\4mp.tif	4	FIX.002.001.000			
2	A	c:\clients\Martin\3mp.tif	1	FIX.002.002.000	■		
2	B	c:\clients\Martin\3mp.tif	2	FIX.002.002.000			
1	A	c:\clients\Martin\3mp.tif	3	FIX.002.002.001	■		
3	A	c:\clients\Smith\2mp.tif	1	FIX.003.000.000	■		
3	B	c:\clients\Smith\2mp.tif	2	FIX.003.000.000			
2	A	c:\clients\Smith\1mp.tif	1	FIX.003.001.000	■		

NOTE: Duplex mode overrides the list file level designation within a grouping. This allows the grouping to be maintained while maximizing the number of images that can be written to one roll of film.

Appendix B TIFFCHKR Functions

Overview

The AWIS program group contains an icon for the AWIS TIFFCHKR application. TIFFCHKR is used to perform one of the following functions:

- Check TIFF header tags for compatibility with the Writer.
- Check file sizes to ensure they will fit on the Writer.
- Run a decompression check on TIFF files to ensure there will be no decompression errors during processing.
- Check number of rows and columns in ASCII files to alert you if the file will be cropped when converted to a TIFF file.
- Convert multi-strip TIFF images to single-strip images.

The TIFFCHKR window

The TIFFCHKR window provides access to the AWIS TIFFCHKR application.

To access the TIFFCHKR window:

- Double-click on the TIFFCHKR icon. The TIFFCHKR window will be displayed:

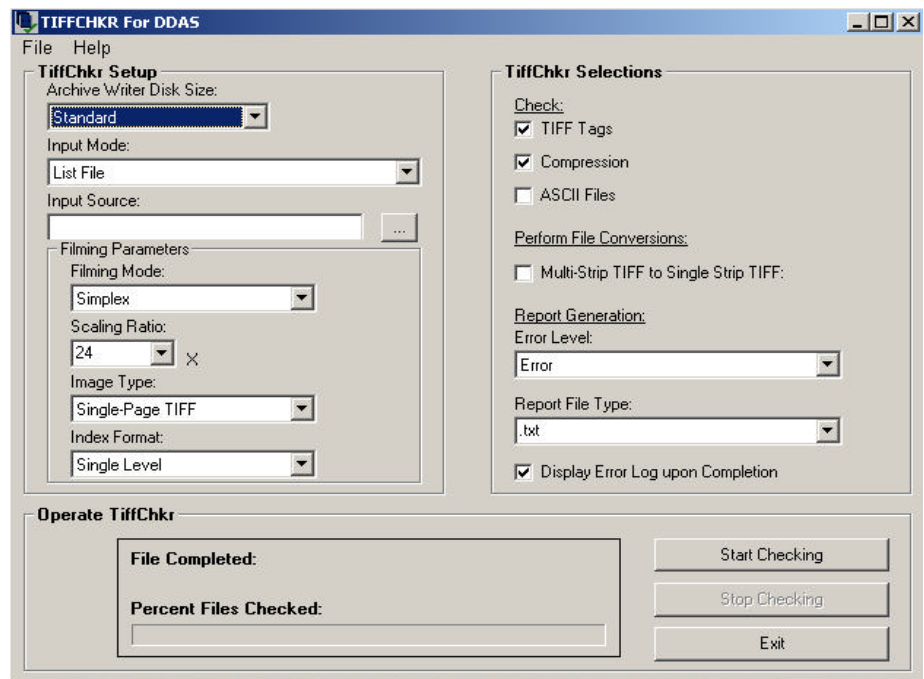

The TIFFCHKR window contains the following fields:

TIFFChkr Setup (all items in this group box are required fields):

- **Archive Writer Disk Size (Mb):** selections are **Standard** (1.4 Mb) or **Enhanced** (8 Mb). This is required to calculate maximum file sizes that will fit on the Writer.
- **Input Mode:** List file, Batch directory or Individual file.
NOTE: Poll mode is not applicable to TIFFCHKR. If your application uses Poll mode, select whichever List file, Batch directory or individual file corresponds to the item indicated by the Poll file in Poll mode.
- **Input Source:** Full path to the List file, Batch directory or single file.
NOTE: If you type a partial path, and end with a "\", select ... (Browse). You will be in the Browse dialog box at the typed-in location.
- **Filming Parameters:**
 - Filming Mode — Simplex or Duplex
 - Scaling Ratio — 20 to 60X
 - Image Type — Single- or Multi-Page
 - Index Format — No Indexing, Single-Level, Two-Level, and Three-Level

TIFFCHKR Selections: allows you to select the TIFFCHKR operations and error checking options to be performed. The selections available include:

- **Check** — TIFF Tags; Compression; ASCII Files.
- **Perform File Conversions** — Multi-strip TIFF to single-strip TIFF. The original file will be changed into a single-strip image. If you need to save the file in multi-strip format, save a copy of the original file.
NOTE: At least one of the checkboxes from the above categories must be selected.

Report Generation:

- **Error Level:**
 - **Error** — Only errors will be reported.
 - **Warning** — Errors and warnings will be reported.
 - **Report File Type:** type the file extension of the report to be generated (maximum of three characters; do not include "." that precedes the file extension).

- **Operate TiffChkr:** when you choose **Start Checking**, the name of the file being checked and a status meter are displayed. The status meter indicates the percent of files in the List or Batch directory that the TIFFCHKR has completed preprocessing.

When the AWIS TIFFCHKR has completed a job, either an Error report or a **No errors encountered** message box will be displayed.

If you select **Stop Checking** while processing a job, the Error report or message box will appear for the files checked. If you select **Start Checking** at this point, processing will restart at the beginning of the job.

NOTE: The Error report will always be named "tiffchkr.xxx". If this report needs to be kept, it should be saved to a different file name. A message box asking if the user wants to delete the existing log file will appear if a log file named "tiffchkr.xxx" already exists. If the existing log file is not deleted, the new information will be appended to the end of the existing file. This file will be placed in the AWIS install directory.

Appendix C Glossary

Advance Film — Instructs the Writer to advance the film the distance specified by the film advance parameter in the Film Template or by a value entered by the operator.

Application — A set of parameters that relates to how a collection of images will be written to film.

Archive Writer — The name of the hardware that writes image files to microfilm. The official name is *Kodak Digital Science Document Archive Writer*, Model 4800.

AWIS — Archive Writer Interface Software. This software provides a high-level interface to the *Kodak Digital Science Document Archive Writer 4800* and the *Kodak i9600 Series Writer*. The software application that controls the Writer.

Beginning of Roll Processing — When a new roll of film is required, the AWIS application initiates the beginning of roll processing, which includes creating a film leader and optionally writing Image Management Code, header pages, and resolution target files.

End-of-Roll Processing — When the operator indicates the roll of film is complete, the AWIS application initiates end-of-roll processing, which optionally includes writing trailer pages. The film is then optionally run to the end of the roll.

Error Handling — In a situation where an image file cannot be written to film, the application pauses and provides the operator the name of the invalid image file. The operator can manually replace the bad image file with a good one. When the operator restarts the writing process, it begins with the replacement image file.

Error Log — This file contains error information logged by the AWIS application.

Film Template — A set of parameters defining the format of the film output.

Header Pages — Optional customer-supplied image files that can be written to the beginning of the film. These images are not indexed.

IMC — Image Management Code. Code written at the beginning of a roll of film, which allows automatic setup of the retrieval device.

Job — A batch of work defined by the image set to be written to film

Roll ID Management — When a new roll of film is required by the Writer, the AWIS application prompts for a new roll identifier and verifies that the name does not currently exist in the AWIS database.

Run Film to End-of-Roll — Runs the film to the end of the physical roll.

Status Reporting — The AWIS application displays information to the user including:

- Remaining film in both cartridges
- Name of last image file written
- Last image address written
- Percentage of the input file collection written
- Number of images written

TIFF — Tagged Image File Format. A standard for storing image data in a file. Image data is stored as CCITT G3, G4, JBIG or uncompressed. Single- and multi-page TIFF files are supported by the Writer. Multi-strip and tiled TIFF files are not supported, but TIFFCHKR can be used to convert multi-strip to single-strip.

Transfer File — An optional file created during the writing of images to film. The information in this file can be used by an external application to update an external database. At a minimum, it contains the original image file name, roll number and the image address assigned to the image. The name of the Transfer file is the same as the roll name, with an extension of .xfr.

Trailer Pages — Optional customer-supplied image files that can be written to the end of the film. These images are not indexed.

Writer — The name of the hardware that writes image files to microfilm. The official name is *Kodak i9600 Series Writers*. Two models are available: *Kodak i9610 Writer*: writes at 4800 scan lines per second and *Kodak i9620 Writer*: writes at 9600 scan lines per second.

Appendix D Index Formats, Image Addresses and Image Marks

Images can be indexed in order to facilitate ease of retrieval. If an index format is specified in the film template, each image is assigned an image address that can be stored in an index database. An image mark is also written in each frame on the left edge of the film, for use by the retrieval device. An image mark can be small, medium or large. The index format determines image mark sizes used, and whether images are written ungrouped, or in groups using a 2-level or 3-level hierarchy. The following index formats are supported by the Writer:

Index Format	Sample Image Address Sequence
No indexing	Images are not assigned an image address, and image marks are not written in the frames. Images cannot be retrieved with automatic methods.
Single-level	1, 2, 3, 4
Two-level	1.0, 1.1, 1.2, 2.0, 2.1
Three-level	1.0.0, 1.1.0, 1.1.1, 1.1.2, 1.2.0, 1.2.1, 2.0.0.

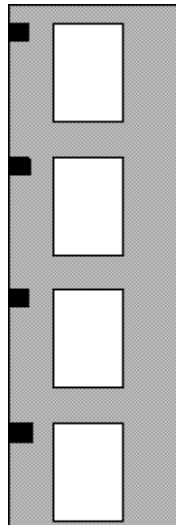

Single-Level — images are not grouped. Every frame is written with a small image mark.

**Simplex
Single-Level**

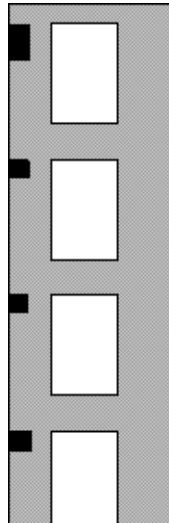

Two-Level — images are grouped using a 2-level hierarchy. The first frame within each group is written with a medium image mark. Subsequent frames within the group are written with a small image mark. Retrievals can be made of an entire group or individual images.

**Simplex
Two-Level**

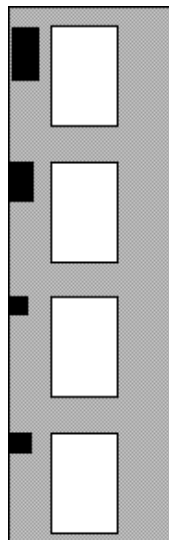

Three-Level — images are grouped using a 3-level hierarchy. The first frame within each group is written with a large image mark. Subsequent frames within the group are written with a medium or small image mark depending on the image level specified via the input mode. Retrievals can be made of an entire group, second-level subgroup, or individual images.

**Simplex
Three-Level**

Level changes are made based on level-to-follow-level rules and image levels specified via input mode. The level-to-follow-level rules are established as part of application setup.

Images should be grouped any time it is necessary to indicate a relationship between images for retrieval purposes. For example, the two-level format could be used to maintain the page relationship of individual multi-page files. The three-level index format could be used to maintain both the page and file relationships of multi-page files within a folder.

NOTE: Grouping can be done with simplex or duplex film mode, but the assigned image addresses will be different. When film mode is simplex, each image is assigned a unique image address. When film mode is duplex, images paired in a frame are both assigned the same image address.

If grouping is not required, and it is not necessary to identify each image with a unique image address, and the goal is to pack the film with as many images as possible, the application setup and film template should specify duplex film mode, the maximum practical scaling and reduction, the smallest interdocument gap, and single-level index format, and the images should be oriented such that the shortest side of each image will be written parallel to the edge of the film.

Image addresses contain 1, 2 or 3 fields, depending on the index format. The fields are delimited with a period. The image address increments as images are written to film, based on image level. The image address may begin with a fixed field containing alphanumeric characters. Only the fixed field may contain alphas. This field will be the same for every image on a roll. Image addresses may contain up to 12 characters. The maximum field size for any field of the image address, including fixed field, is 9 characters (8 in the fixed field if alphas are being used).

Image levels

The Writer supports multiple image levels to allow for image grouping. The image level is specified via the input mode. The number of levels allowed is dependent on the index format. An image can also be designated as level 0, which is written to film with no assigned image address, and the frame does not receive an image mark.

Use of Level 0 should be limited as the images are not retrievable by automated methods. Appropriate use includes images used for film test and quality control purposes that are not part of the retrieval index database.

Appendix E Image File Specifications

This appendix details the specifications of the digital image files to be written to film. The Writer receives images to write to film from the application software through an Ethernet network interface. The application software only accepts image files in TIFF image format or ASCII text files.

TIFF file format

The TIFF image file format header contains data that identifies it as a TIFF file. The remaining data in the file are sets of TAG data followed by image data. The TAG data contains information, such as image length and width. Each TAG has a unique number followed by a value field. The TAG numbers used below have been accepted and published in the TIFF Standards document (*TIFF 6.0 Specification*, Aldus Corporation, June 3, 1992; search for TIFF6.PDF at Default_XREF_styleREF[http:// www.adobe.com](http://www.adobe.com)). If there is more than one set of TAG and data sections, it is a multi-page TIFF file.

TIFF input file specifications

Image files accepted by the Writer must conform to the following specifications:

- Baseline conformance with the TIFF 6.0 Specification, including extensions for Group III, IV and JBIG compression types. Group IV compression is recommended.
- Bi-tonal.
- Single- or multi-page.
- Single-strip only. Rows per strip must equal image length. (TAG #278 must equal TAG# 257)

The TIFF tag fields that **must** be designated are:

- **X Resolution** — numeric; measured in pixels. TAG #282
- **Y Resolution** — numeric; measured in lines. TAG #283
- **Compression type** — note that options must also be specified when using Group III compression. TAG #259
- **Image width** — numeric; measured in pixels. TAG #257
AWIS validation occurs on the scaled image width, which is derived from this value and the desired scaling specified in film template setup. Valid scaled image width values are:
 - 1 to 3888 pixels (simplex mode)
 - 1 to 1920 pixels (duplex mode)

Image length — numeric; measured in lines. AWIS validation occurs on the scaled image length, which is derived from this value and the desired scaling specified in film template setup. Valid scaled image length values: 1 to 6900 lines. TAG #257

The following TIFF tag fields **should** be designated. If not, default values will be used. This may or may not result in the image being correctly represented.

TAG #	Field	Default
258	Bits per sample	1
296	Resolution unit	Inches
262	Photometric interpretation	1=black
278	Rows per strip	=image length

TIFF compression types supported

The following compression types are supported:

- TIFF type 1 — no compression
 - TIFF type 2 — CCITT Group III, 1-dimensional
 - TIFF type 3 — CCITT T4 bi-level encoding
 - TIFF type 4 — CCITT T6 bi-level encoding (recommended)
 - JBIG — JBIG compression

Using JBIG compressed files

A JBIG compressed image file consists of a 20-byte header followed by the image data*. For use in the Writer the JBIG header and image data should not be modified. However, in order for the system to read and decompress these files, they must be enclosed in a TIFF file format wrapper.

The TIFF tags/fields that **must** be designated in the TIFF wrapper are:

- **X resolution** — must be provided; it cannot be derived from the JBIG file header. Numeric; measured in pixels. TAG #282
- **Y resolution** — must be provided; it cannot be derived from the JBIG file header. Numeric; measured in lines. TAG #283
- **Compression type** — must be: 34461 (0x8765). TAG #259
- **Image width** — set to the 'Xd' field found in the JBIG header. TAG #257
- **Image length** — set to the 'Yd' field found in the JBIG header. TAG #257

* ITU-T Recommendation T.82, "Information Technology - Coded Representation of Picture and Audio Information - Progressive Bi-level Image Compression", 03/93.

- **Rows per strip** — must be the same as the image length for a compliant single-strip TIFF with compression. (TAG #278 must equal TAG #257)
- **Strip offsets** — must point to the JBIG 20-byte header. TAG #273
- **Strip byte counts** — must be the number of bytes in the JBIG file. TAG #279
- **JBIG header and image data** — the JBIG header must be incorporated as the first 20 bytes of the JBIG image data.

The bits-per-sample, resolution unit and photometric interpretation (if not present) should be designated, but if not, will be set to the default values shown earlier.

Restrictions for JBIG compression

The JBIG compressed file must be a single-strip only. Multi-strip images are not supported.

- The following bits must be 0 in the JBIG header:
 - Order field: HITOLO, SEQ, ILEAVE, SMID
 - Options field: TPDON, DPON, DPPRIV, DPLAST
- The P field in the JBIG header must be 1 (single-plane only).
- The TIFF tag field of JBIGOptions is not supported.

TIFF maximum file sizes

The Writer has an internal CPU with its own operating system. This CPU has no mass storage device (such as a hard drive) so its memory is organized into system and data storage areas. The data storage area is configured as if it were an external storage device (a DOS RAM disk). This is where image data is buffered before being written to film.

When duplex mode is used, the image storage space is divided between the two images.

Blank TIFF image (blank.tif)

Depending upon the desired grouping of images on film, it may be necessary to insert a space between images or groups of images on the film. A 1 KB blank image (blank.tif) is provided to use as a spacer. This blank.tif can be found in the install directory for AWIS (usually c:\Program Files\AWIS). This file is designed to process quickly and efficiently.

Text input file specifications

ASCII text files must conform to a maximum of 66 lines and 80 characters per line. Files which exceed these limits will be processed by the system, but will be truncated and the truncated data will not be written to film. Text files are often used as header and trailer pages. AWIS converts any text files to TIFF format prior to writing to film.

Image file names

All file names must conform to the Windows NT file naming convention. Long file names, up to 255 characters (including the directory path), are allowed.

TIFF files do not need the “.tif” extension, but must have some type of three-character file extension. The data in the TIFF file header verifies that it is a TIFF formatted file.

The required extension for text files is “.txt” (not case sensitive).

Examples

```
\image123.tif  
c:\pollcache\Electronic Microimager\batch001\00000001.tif  
c:\app1\image File 234.001  
f:\titles\monroe\image1.tif  
c:\BeginRoll\application1\start.txt
```

EASTMAN KODAK COMPANY
Document Imaging
Rochester, New York 14650

Kodak is a trademark of Eastman Kodak
Company.

Printed on recycled paper.

A-61056 3/03
CAT No. 881 4832
©Eastman Kodak Company, 2003
Printed in U.S.A.

DOCUMENT
IMAGING

